

Introduction

Motion Control Coordinate System

Any positioning stage is considered to have six *degrees of freedom*: three linear, along the **x**, **y**, and **z** axes; and three rotational about those same axes (Figure 1).

All motions described here are with respect to a right-handed coordinate system. All movements

can be considered to be composed of translations along and/or rotations about the coordinate axes.

One key differentiating feature of Newport products is how well motion is constrained in all but the desired directions. In other words, if very “straight” motion in the **x** direction is required, then the stage must be well constrained from moving in the five *off-axis* directions (Figure 9).

Important Specifications

There are many different measures of performance to consider when choosing a particular positioning stage. Understanding the definitions of the various parameters and how they affect performance will simplify the selection process.

Minimum Incremental Motion

The smallest *motion* a device is capable of delivering reliably. Not to be confused with *resolution* claims, which are typically based on the smallest *controller display increment* and which can be more than an order of magnitude more impressive than the actual motion output. This is a key distinction but is rarely disclosed.

Resolution

The smallest position increment that a motion system can *detect*, which is not the same as the *minimum incremental motion*. Also referred to as *display or encoder resolution*, it is usually determined by the encoder output, but due to inefficiencies in the drive-train—like hysteresis, backlash and windup—most systems cannot make a minimum incremental move equal to the resolution unless the encoder is directly measuring the delivered motion. See the discussion on direct output metrology in the section on Feedback Devices, page 7-15.

Sensitivity

The minimum input capable of producing output motion (most often used to describe motion in manual stages). It is also defined as the ratio of the output motion to input drive. This term is often used incorrectly in place of *resolution*.

Accuracy

The maximum *expected* difference between the actual and the ideal (desired) position for a given input (Figure 3). Accuracy of a motion device is highly dependent on how the actual position is measured. Therefore accuracy is not a meaningful specification for open-loop devices.

Absolute Accuracy

The output of a system versus the commanded or ideal input; it is more intuitively called *inaccuracy*. When a motion system that is commanded to move 10 mm actually moves 9.99 mm as measured by a perfect ruler, the inaccuracy is 0.01 mm. Misalignment of the stage axis versus the ruler’s axis will result in a monotonically increasing inaccuracy proportional to the cosine of the misalignment. This is commonly referred to as *cosine error*.

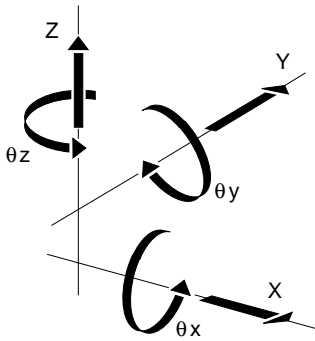

Figure 1 — Right-handed coordinate system showing six degrees of freedom.

On-Axis Accuracy

The uncertainty of position after all sources of linear error are eliminated. Linear (or monotonically increasing) errors include cosine error, inaccuracy of the leadscrew pitch, the angular deviation effect at the measuring point (*Abbe error*) and thermal expansion effects. Graphically these errors are represented by the slope of a best fit line on a plot of position versus error (Figure 2). Knowing the slope of this line (error/travel), we can approximate *absolute accuracy* as:

Absolute Accuracy = On-Axis Accuracy + Slope x Travel.

For stages with direct-output metrology such as a linear glass scale, the slope approaches zero and the absolute accuracy becomes the same as the on-axis accuracy.

Precision

The range of deviations in output position that will occur for 95% of the motion excursions from the same error-free input. Precision is also known as *repeatability*. Although often confused in common parlance, *accuracy* and precision are not the same. Figure 3 shows graphically the difference between these two parameters.

Repeatability

The ability of a motion system to reliably achieve a commanded position over many attempts. Manufacturers often specify *uni-directional repeatability* which is the ability to repeat a motion increment in one direction only. This specification side-steps issues of backlash and hysteresis, and therefore is less meaningful for many real-world applications where reversal of motion direction is common.

A more significant specification is *bi-directional repeatability*, or the ability to achieve a commanded position over many attempts regardless of the direction from which the position is approached. Few other manufacturers publicize this much tougher measure of motion performance.

Backlash

The maximum magnitude of an input that produces no measurable output upon reversing direction. It can be a result of insufficient axial preloads or poor meshing between drivetrain components, i.e., gear teeth in a gear-coupled drivetrain. Backlash is relatively repeatable and can be compensated for by capable controllers.

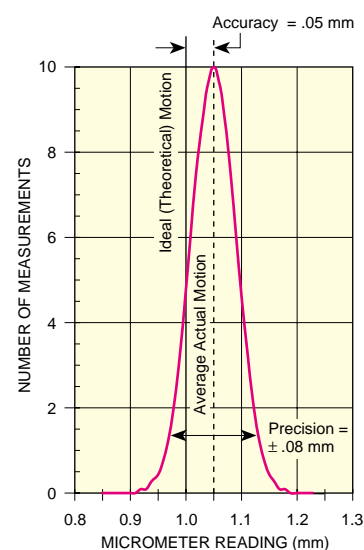

Figure 3 — The difference between accuracy and precision.

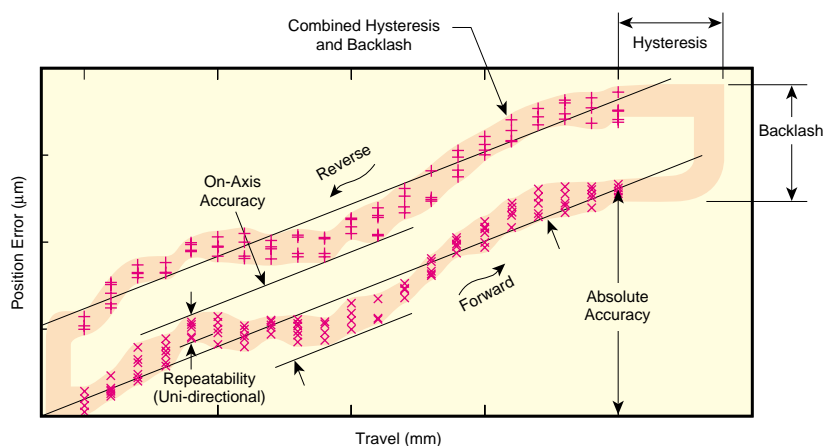

Figure 2 — Error vs. position for a stage translated four times in each direction. This figure shows graphically the difference between backlash and hysteresis.

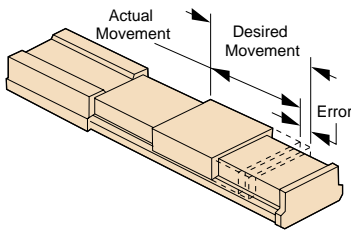

Figure 4 — Position error in a translation stage.

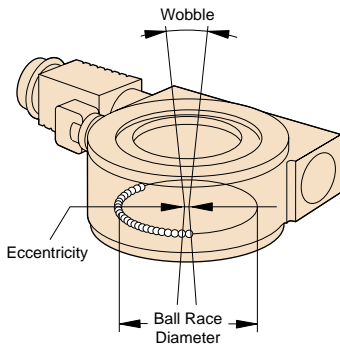

Figure 5 — Off-axis errors in a rotary stage.

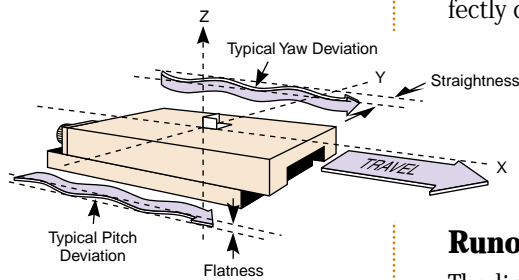

Figure 6 — Off-axis errors in a linear stage.

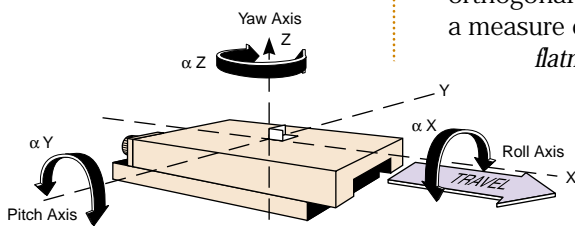

Figure 7 — Roll, pitch, and yaw are defined with respect to the direction of travel.

Hysteresis

The difference in the absolute position of an object for a given commanded input when approached from opposite directions (Figure 2). It is due to elastic forces accumulated in various drivetrain components (leadscrew wind-up, for instance). This is often confused with *backlash* which can be characterized and compensated for by capable controllers.

Error

The difference between an obtained performance parameter and the ideal or desired result. Errors fall into two primary categories. *On-axis errors* (Figure 4), like accuracy, relate to parameters along the direction of travel. *Off-axis errors*, like pitch error, relate to parameters along the constrained degrees of freedom.

Eccentricity and Wobble

Sometimes called concentricity, eccentricity in a rotary stage is the deviation of the center of rotation from its mean position as a stage turns (Figure 5). If a stage were perfectly centered, there would be no eccentricity as it rotated.

For a rotary stage, wobble is the angular deviation of the axis of rotation over one revolution.

Runout

The linear (versus angular) portion of off-axis error. It is the deviation between ideal straight line motion and actual measured motion in a translation stage. Runout has two orthogonal components, *straightness*, a measure of in-plane deviation, and *flatness*, the out-of-plane deviation (Figure 6).

Tilt and Wobble

The angular portion of off-axis error. It is the deviation between ideal straight line motion and actual measured motion in a translation stage. Tilt and wobble have three orthogonal components commonly referred to as *roll, pitch, and yaw* (Figure 7). These terms usually dominate the overall error due to the geometry of the motion system.

Abbe Error

Additional linear off-axis error introduced through amplification of tilt and wobble with a long moment arm (Figure 8). This type of error occurs when the point under measurement is a relatively long distance from the axis of motion. For example, XYZ stages incorporating an angle bracket between the moving elements will exhibit measurable Abbe error since the Z stage is significantly displaced above the X and Y axes. It appears as runout, but unlike true runout, Abbe error can be minimized by reducing the lever arm.

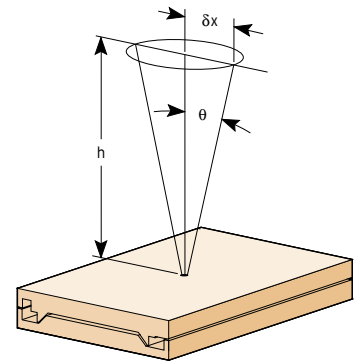

Figure 8 — Abbe error can be reduced by minimizing the height, h , from the stage surface.

Play

Uncontrolled movement due to looseness of mechanical parts. It is very small in a well-built component and can increase as a component grows older, especially if it is roughly handled or overloaded. Play is a contributor to *backlash*.

Friction

Friction is defined as the resistance to motion between surfaces in contact. Friction can be constant or it can vary with speed. Elements contributing to overall friction may be in the form of drag, sliding friction, system wear or lubricant viscosity.

Stiction

The static friction that must be overcome to impart motion to a body at rest. Since static friction is higher than sliding friction, the force which must be applied to impart motion is greater than the force required to keep the body in motion. As a result, when a force is initially applied, the body will begin to move with a “jump” at some unpredictable and unrepeatable force threshold, giving a non-linear, non-repeatable motion that controllers cannot compensate.

Position Stability

The ability to maintain a constant position over time. Variation from a stable position is called *drift*. Contributors to drift include worn parts, migration of lubricant, and thermal variation.

Load Capacity

The allowable resultant force due to load applied at the center of the stage carriage with a direction perpendicular to the axis of motion and carriage

surface for linear stages (Figure 10). For rotary stages, the direction of the resultant force is along the axis of rotation. For loads with a resultant force which is not centered, the specified load capacity must be derated appropriately.

One of the primary determinants of a stage’s load capacity is the bearing system. See the Bearings section for further discussion.

Normal Load Capacity

The maximum centered load that can be placed directly on the moving carriage. It is typically limited by the load capacity of the bearings in a motion stage.

Transverse Load Capacity

Also called *side load capacity*, it is the maximum load that can be applied perpendicular to the axis of motion and along the carriage surface. This is usually limited by the load capacity of the bearings and is typically smaller than the normal load capacity since fewer of the bearings carry the load.

Axial Load Capacity

The maximum load along the direction of the drivetrain. For linear stages mounted vertically, the specified vertical load capacity is usually limited by the axial load capacity. Most often, axial load capacity is determined by the load capacity of the motor and leadscrew.

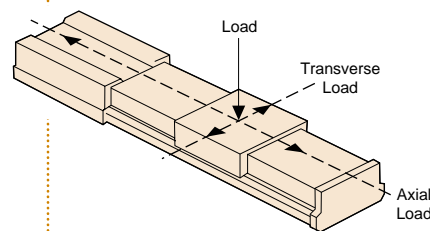

Figure 10 — Load capacity specifications refer to loads which are centered and perpendicular.

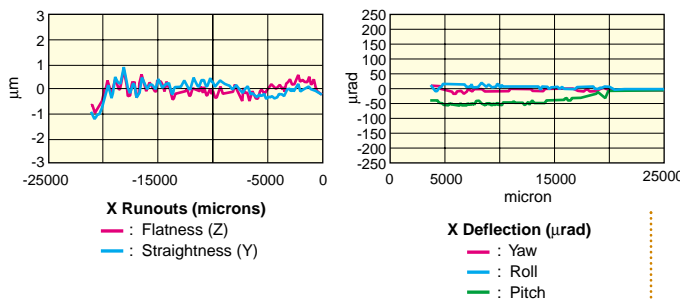
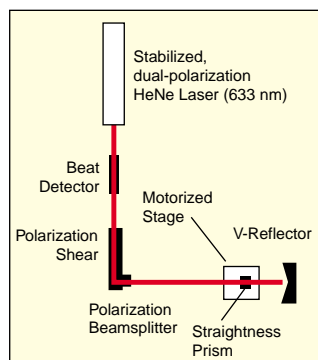

Figure 9 — Simplified schematic of Newport’s interferometric test setup for measuring off-axis errors and sample test results. High quality translation stages have sub-micron runout errors with angular deviations on the order of 100–150 µradians.

Derating Normal Load Capacity for Off-Axis Loads

Selecting a stage requires understanding system load requirements and how the load is applied to the stage.

If the load is cantilevered, the allowable load capacity must be derated using the cantilever equation shown below.

The cantilevered load derating equation is:

$$C = Q (1 + D/a)$$

where:

C is the equivalent centered load

Q is actual applied load

D is the distance from the center of the carriage in centimeters

a is a stage specific constant related to the bearing geometry

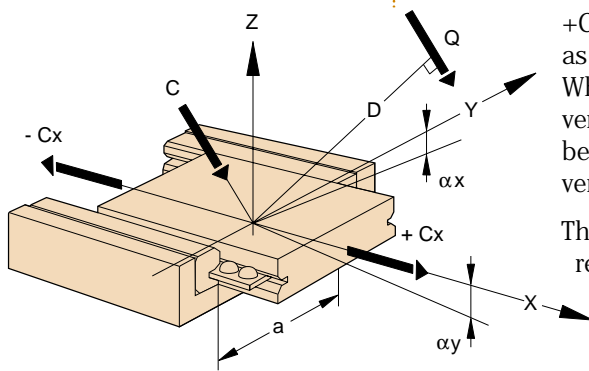

Figure 11 — Selecting the proper stage requires an understanding of how loads are applied.

+Cx in Figure 11 is defined as away from the motor. When a stage is positioned vertically, the motor must be on top to meet stated vertical load capacity.

The angular deflections resulting from the off-center load are:

$$\alpha_x = k_x Qdx$$

$$\alpha_y = k_y Qdy$$

$$\alpha_z = k_z Qdz$$

where :

Qdx, Qdy and Qdz are the projections of the torque applied by Q onto the x, y and z axes.

Dynamic Load

The sum of all static loads and dynamic resistance to motion. Some dynamic characteristics of the load that need to be considered include friction and inertia. Dynamic load must be considered when evaluating overall performance of a motion system since it limits the system's achievable acceleration.

Velocity (Speed)

The change in distance per unit time. Specifications for maximum speed are stated at the normal load capacity of the stage. Higher speeds may be possible with lower loads. Minimum stated speeds are highly dependent on a motion device's speed stability. As stated in this catalog, velocity (a vector) and speed (a scalar) are used interchangeably.

Speed Stability

The ability to maintain a constant speed motion. Also specified as *velocity regulation*, this parameter depends upon the stage's mechanical design, its feedback mechanisms, the control algorithm used and the magnitude of the speed. See the discussion on tachometers in the Feedback Devices section, page 7-15.

Acceleration

The change in velocity per unit time.

Inertia

The measure of a load's resistance to change in velocity. The larger the inertia, the greater the torque required to accelerate or decelerate the load. Inertia is a function of a load's mass and shape. If there is a constraint on the amount of torque available, then the allowable acceleration and deceleration times must be increased.

MTBF

MTBF, or Mean Time Between Failure, is a measure of stage reliability. It is defined at a rated load and duty cycle. Quoting an accurate value for this important specification is difficult due to the extensive testing involved.

Mechanical Stage Design

Materials

Each material used for mechanical components in motion control has its own unique set of advantages and disadvantages. Following is a summary of the properties for the most common materials used in motion mechanics.

Stiffness

A measure of the amount of force required to cause a given amount of deflection. Force and deflection are proportional and related by the equation:

$$F = kx$$

where F and x are force and deflection respectively and k is a material dependent constant of proportionality called the *modulus of elasticity*. A material is stiffer for larger values of k .

Thermal Expansion

Temperature changes cause size and shape changes in a stage. The amount of change is dependent on the size of the component, the amount of temperature change, and the material used. The equation relating dimensional change to temperature change is:

$$\Delta L = \alpha L \Delta T$$

where α is the material dependent coefficient of thermal expansion.

Thermal Conductivity

Some materials, such as aluminum, are good choices when temperature change across the component is non-uniform. This occurs when mounting a heat source such as a laser diode. Because the diode is hotter than the surrounding environment, it dissipates heat through the mount setting up a temperature gradient along the stage. If the material does not readily dissipate the heat, then distortions caused by thermal gradients can become significant.

The distortion caused by non-uniform temperature changes is proportional to the coefficient of thermal expansion, α , divided by the coefficient of thermal conductivity, c .

$$\text{Relative thermal distortion} = \alpha/c$$

If the ambient operating temperature of the component is much different from room temperature, then close attention should be paid to components made with more than one material. In a translation stage, for example, if the stage is aluminum while the bearings are stainless steel, the aluminum and steel will expand at different rates if the temperature changes and the stage's bearings may lose preload or the stage may warp due to stresses which build up at the aluminum-steel interface.

Material Instability

The change of physical dimension with time; so called cold flow or creep. For aluminum, brass and stainless steel, the period of time required to see this creep may be on the order of months or years.

Aluminum

Features

Aluminum is a lightweight material, resistant to cold flow or creep, with good stiffness-to-weight ratio. It has a relatively high coefficient of thermal expansion, but it also has a high thermal conductivity, making it a good choice in applications where there will be thermal gradients or where rapid adjustment to temperature changes is required. Aluminum is fast machining, cost effective, and widely used in stage structures. Aluminum doesn't rust and corrosion is generally not a problem in a typical user's environment, even when the surface is unprotected. It has an excellent finish when anodized.

Limitations

Anodized surfaces are highly porous, making them unsuitable for use in high vacuum.

Coatings

Anodized aluminum provides excellent corrosion resistance and a good finish. Black is the color most often used. Anodizing hardens the surface, improving scratch and wear resistance. Aluminum may also be painted with excellent results.

Steel**Features**

Steel has a high modulus of elasticity, giving it very good stiffness (nearly three times that of aluminum), and good material stability. It also has about half the thermal expansion of aluminum (Figure 12), making it an excellent choice for stability in typical user environments where there are uniform changes in temperature. Stainless steel is well-suited to high vacuum applications.

Limitations

Machining of steel is much slower than aluminum, making steel components considerably more expensive. Corrosion of steel is a serious problem but stainless steel alloys minimize the corrosion problems of other steels.

Coatings

Steel parts are generally plated or painted. Platings are often chrome, nickel, rhodium, or cadmium. A black oxide finish is often used on screws and mounting hardware to prevent rust. Stainless steel alloys avoid the rust problems of other steels. They are very clean materials which do not require special surface protection. A glass-bead blasted surface will have a dull finish which does not specularly reflect.

Brass**Features**

Brass is a heavy material, denser than steel, and fast machining. The main use of brass is for wear reduction; it is often used as a dissimilar metal to avoid self-welding effects

with steel or stainless steel lead-screws or shafts. Brass is used in some high precision applications requiring extremely high resistance to creep and can be diamond turned for extremely smooth surfaces.

Limitations

Compared to aluminum and steel, brass has a less desirable stiffness-to-weight ratio. Also, despite that the thermal expansion of brass is similar to that of aluminum, its thermal conductivity is nearly a factor of two worse.

Coatings

For optical use, brass is usually dyed black. In other cases, it may be plated with chrome or nickel for surface durability.

Granite**Features**

Granite's unique physical characteristics, combined with new advances in machining methods, make granite structures one of the best choices for air-bearing support structures. The flatness of the surface is often a major factor in the positioning accuracy and repeatability of the total system.

The polished granite surfaces of these structures are among the flattest commercially available—typically ± 15 microns per square meter. Skilled hand-lapping produces geometrically perfect surfaces that exceed the flatness of surfaces produced by automated equipment of any kind.

An important characteristic of granite is its extreme hardness, which enables it to be lapped to very tight flatness specifications. Tests confirm that granite is more wear-resistant and shock-resistant than steel. Granite's high strength makes it particularly suitable to large-scale systems with heavy static loads. Granite is also non-magnetic, making it excellent for electron beam applications, and is not affected by most chemicals.

The outstanding dimensional stability of granite also contributes to its usefulness in precision support structures. Granite is completely free of

internal stresses which results in uniform, predictable response to thermal changes. Granite's high mass also gives it high thermal inertia, which protects experiments and processes from being affected by short-term ambient temperature fluctuations.

Limitations

For large structures and table surfaces the mass of a granite structure can become large. For applications where extreme flatness is not important, steel honeycomb structures offer

Parameter	Steel	Aluminum
Stiffness, k (Mpsi)	28	10.5
Density, ρ (lb/in ³)	0.277	0.097
Specific Stiffness, k/ρ	101	108
Thermal Expansion, α (μin/in/°F)	5.6	12.4
Thermal Conduction, c (BTU/hr-ft-°F)	15.6	104
Relative Thermal Distortion, α/c	0.36	0.12

Figure 12 — Properties for common stage materials.

better weight to stiffness properties and can be damped for specific frequencies to optimize system performance.

Bearings

Bearings permit smooth low-friction rotary or linear movement between two surfaces. Bearings employ either a sliding or rolling action. In both cases, the bearing surfaces must be separated by a film of oil or other lubricant for proper performance.

The load and trajectory performance of a translation or rotation stage is primarily determined by the type of bearings which are used.

Ball Bearings

Ball bearing slides reduce friction by replacing sliding motion with rolling motion. Balls are captured in guide ways by means of vee-ways or hardened steel rods as shown in Figure 13. The guide ways are externally loaded against the balls to eliminate unwanted runout in the bearings. Even with this preload, the friction is very low resulting in extremely smooth travel. Ball bearing slides are relatively insensitive to contamination because each ball contacts the guide ways at only a single point, allowing debris to be pushed out of the way.

With a vee-groove bearing way, ball bearings have a lower load capacity than crossed-roller bearings, since the contact area available to transmit loads is smaller; so in order to carry the same size load, the balls would

need to have a larger diameter or be higher in quantity.

If the mating ways are ground with either an arch or circular groove (Figure 14), the closer conformity to the balls' radii allows the use of smaller balls than with flat ways. The arch approximates a Vee shaped way with the load effectively split at angles of about 45 degrees with the vertical into two loads on the way.

A circular shaped way has a higher load capacity, but the balls bear the load on the bottom of the groove which can result in side play for loads that are perpendicular to the direction of motion.

Crossed-Roller Bearings

Crossed-roller bearings (Figure 15) offer all of the advantages of ball bearings with higher load capacity and higher stiffness. This is a consequence of replacing the point contact of a ball with the line contact of a roller.

Bearings of this type require more care during manufacture and assembly which results in higher costs. Reserve crossed-roller slides for applications which require the greatest stability, stiffness and robustness.

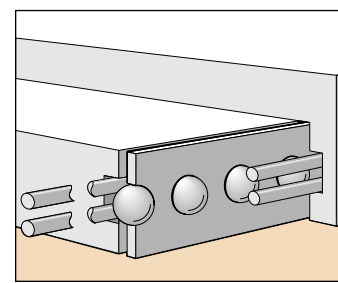

Figure 13 — Ball bearing slides have extremely low friction with moderate load capacity.

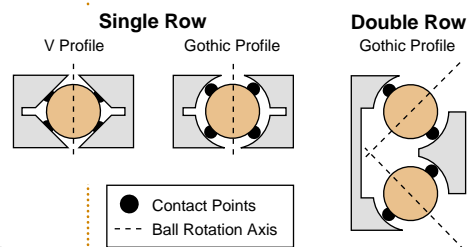

Figure 14 — The type of bearing way, ball diameter and number of balls affect the load capacity of a stage.

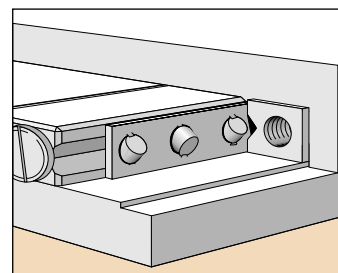

Figure 15 — Crossed-roller bearings have all the advantages of ball bearings with greater stiffness and load capacity.

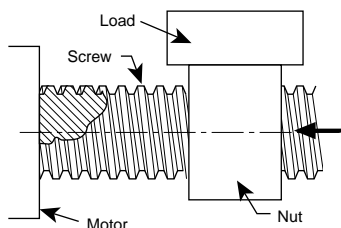

Figure 16 — As the lead screw rotates, the load is translated in the axial direction of the screw.

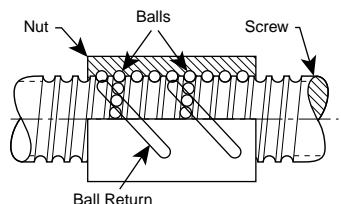

Figure 17 — Ball screws use recirculating balls to reduce friction and gain higher efficiency than conventional lead screws.

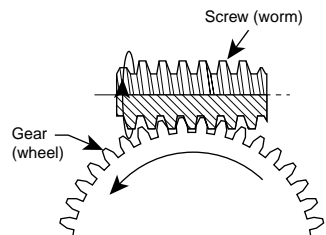

Figure 18 — Worm drive systems can provide high speed and high torque.

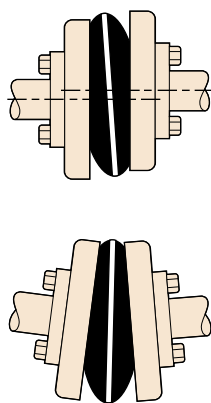

Figure 19 — Shaft couplings adjust for and accommodate angular and parallel misalignment between rotating shafts.

Common drive systems for linear and rotary precision positioning mechanics include the lead screw, ball screw and worm drive. Shaft couplings and gearboxes, which effect system dynamics such as speed, load capacity, backlash, and drive stiffness are located between the drive system and the motor driving it. Gearboxes are most often integrated with the motor.

Lead screw

A very popular technique for moving loads is to use the axial translation of a nut riding along a rotating screw (Figure 16). Lead screws use sliding contact, so their wear rate is directly proportional to usage. The advantages of lead screws include self-locking capability, low initial costs, ease of manufacture and a wide choice of materials.

Recirculating Ball Screw

Recirculating ball screws are essentially lead screws with a train of ball bearings riding between the screw and nut in a recirculating track (Figure 17). The large number of mating parts makes tolerances critical and thus manufacturing costs higher. The screw profile has a rounded shape to conform to the recirculating balls. The primary advantage of ball screws over lead screws is higher efficiency, or the amount of energy output for energy input. However, because it cannot self-lock, a ball screw requires an auxiliary brake to prevent back driving. Additional advantages of ball screws are predictable service life and lower wear rate.

Worm Drive

The worm gear system is a method of transforming rotary motion in one direction into rotary motion in another direction by meshing a screw (worm) with a gear. As the screw is turned, the worm threads meshing with the gear cause it to rotate (Figure 18). Advantages of worm drives over

direct drives include higher velocity ratios and higher load capacities.

Gearboxes

Gearboxes are used to transmit rotational motion and power. They are frequently used in reduction to produce increased resolution that may be difficult or impossible to produce with standard motors. A 10:1 gearbox, for example produces one turn of its output shaft for every 10 turns of its input shaft. A 200-step motor with this gear combination would be viewed as a device which has an effective resolution of 2000 points per revolution of the output shaft.

In addition to changing resolution, gearboxes with non-unity gear ratios also change the available output torque and speed. In the example above, the torque is increased and the speed is decreased.

Flexible Shaft Couplings

Couplings are used in a drivetrain to transmit power and motion between two independent shafts which may not be perfectly aligned (Figure 19).

Flexible couplings generally allow for some parallel and angular misalignment. Depending on their design, they may accommodate more misalignment, have higher torsional stiffness and load capacity, or be capable of higher speeds (Figure 20).

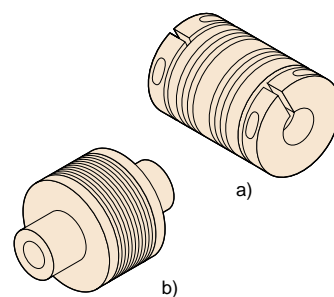

Figure 20 — Flexible couplings are made from many designs.

- a) Helical. No backlash and constant velocity under misalignment. Adaptable to high speed applications.
- b) Bellows. Generally for light-duty applications. Misalignments to 9° angular; 1/4" parallel. Good to 10,000 rpm.

Manual Drives

A manual drive can be described as a high sensitivity leadscrew attached to a knurled knob. The sensitivity depends mainly on a comfortable hand position for the operator. With the manual drives that Newport provides, we specify a sensitivity of one micron. This assumes that the knob has a diameter of 30 millimeters and drives a leadscrew pitch of one millimeter. If reduction gears are incorporated, sensitivity of 0.1 microns is possible.

Stepper Motors

A stepper motor operates using the basic principle of magnetic attraction and repulsion. Steppers convert digital pulses into mechanical shaft rotation. The amount of rotation is directly proportional to the number of input pulses generated and speed is relative to pulse frequency. A typical stepper motor has a permanent magnet and/or an iron rotor with a stator. The torque required to turn the stepper motor is generated by commutating the motor as illustrated in Figure 21.

Commutation

The first difference to understand between a DC and a stepper motor is that when a voltage is applied to a DC servo motor, it will develop both torque and rotation. When a voltage is applied to a stepper motor it will develop only torque. For the motor to rotate, the current applied must be commutated or switched.

Commutation is the principle by which the amplitude and direction of the current flowing in the electro-magnetic coils within the motor changes. A

brushed DC motor is designed to self-commutate while a stepper motor lacks internal commutation.

By applying current to the electro-magnetic windings, stepping motors are able to move in a continuous point-to-point positioning manner. When at rest, a full-step motor's stop position does not drift because there is an inherent holding or *detent torque* without power applied. For this reason, steppers at rest generate little heat making them suitable for position-and-hold vacuum applications where heat dissipation is more difficult.

The three primary types of stepper motors are *permanent magnet*, *variable reluctance* and *hybrid synchronous*.

Permanent Magnet

Permanent magnet motors have a permanent magnet armature magnetized perpendicular to the rotation axis. By energizing four phases in sequence, the rotor will rotate as it follows the changing magnetic field. For the motor depicted in Figure 21, the step angle is 90°. Typical step angles for permanent magnet motors are 45° and 90°. They step at relatively low rates but have high torques and good damping characteristics.

Variable Reluctance

Variable reluctance motors differ from permanent magnet motors by having a multi-tooth armature, each tooth being an individual magnet as shown in Figure 22. At rest, these magnets align themselves in a natural detent position providing larger holding torque. In the example shown, by alternately de-energizing pole 1 and energizing pole 2, the armature rotates 15°.

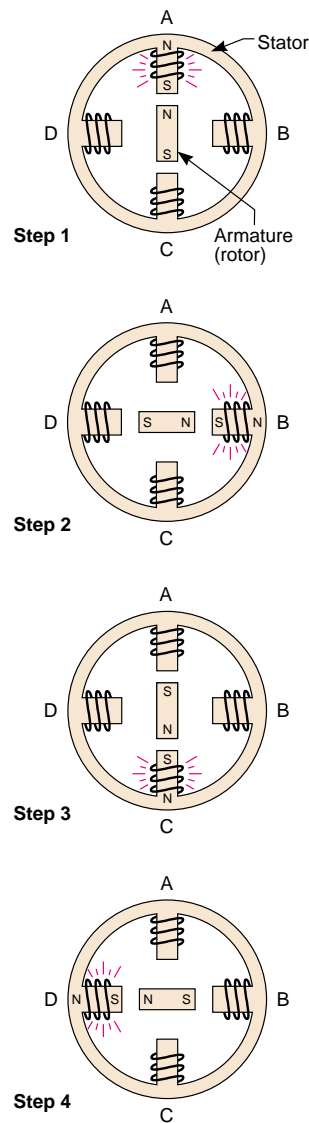

Figure 21 — Rotation in a stepper motor is generated by alternately energizing and de-energizing the poles in the motor's stator creating torque which turns the rotor.

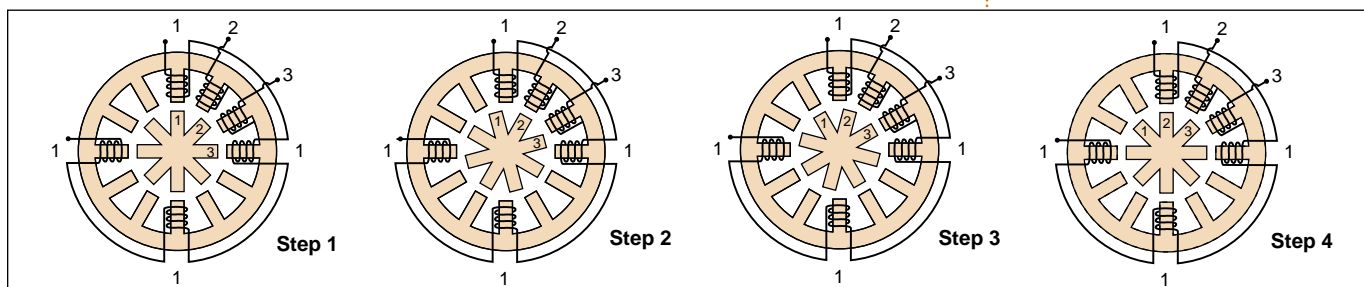

Figure 22 — In a variable reluctance motor, the multi-tooth armature provides higher holding torque at each 15° rotary step. Motion is accomplished through coordinated energizing of the stator poles from step 1 through 4.

► **Hybrid Synchronous**

The hybrid synchronous stepper motor combines the advantages of variable reluctance and permanent magnet stepper motors. The hybrid has multi-toothed stator poles and a multi-toothed armature (Figure 23). These types of motors exhibit high detent torque, excellent dynamic and static torque, and can achieve high stepping rates.

Hybrids usually have two windings on each stator pole so that the pole can be either a magnetic north or south depending on the direction of current flow. Hybrid motors are manufactured in a large torque range by varying both length and diameter.

DC Brush Motors

A brushed DC motor consists of a cylinder shaped armature with windings running parallel to the cylinder's axis. These windings interact with the magnetic field of the stator causing the armature to rotate when voltage is applied. To generate continuous smooth motion with constant torque, the magnetic fields of the armature and stator must be kept at a constant magnitude and relative orientation. This is accomplished by constructing the armature as a series of windings which can be electrically commutated using two brushes to electrically connect the armature.

DC motors are best characterized by their smooth motion at high speeds. A DC motor rotates continuously when its windings are energized, and stops only when its windings are de-energized. For accurate and reliable positioning, an encoder is required to provide position feedback.

Actuators

Actuators, as discussed here, move a payload by extending and retracting a shaft by some electromechanical means. To minimize backlash and hysteresis, the payload is often pre-loaded against the actuator shaft using a spring.

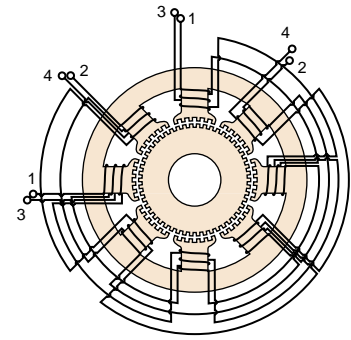

Figure 23 — Hybrid synchronous stepping motors gain superior performance by combining the best of permanent magnet and variable reluctance stepping motors.

Rotating Spindle

Many actuators use the torque from the motor to turn and extend a screw. Using this technique means that the actuator tip will be rotating against the payload surface. This introduces problems with eccentricity and unevenness at the tip which can be minimized by rounding the actuator's tip to reduce contact to a very small area. An advantage of a rotating spindle design is small package size.

Non-Rotating Spindle

A better approach is to use actuators with non-rotating spindles such as piezoelectric or electrostrictive actuators or motorized actuators with specially designed spindles.

Although piezoelectric devices are excellent for sub-micron positioning they lack repeatability because of their inherently high hysteresis and creep.

Electrostrictive actuators have been developed that provide open-loop positioning repeatability improvements over piezo devices of an order of magnitude or more. These actuators offer minimum incremental motion as fine as 0.04 μm .

Electrostrictive materials are similar to piezoelectric materials in that both are ferroelectric crystals which expand and contract in proportion to an applied voltage. However, the electrostrictive actuators use a lead-magnesium-niobate (PMN) crystal

stack while piezoelectric actuators use lead-zirconate-titanate (PZT) based ceramics. The PMN stack is a multi-layer configuration with very thin layers (125 to 250 microns) that are diffusion bonded during the manufacturing process. The net positive displacement is a superposition of the strain from the individual layers.

For PMN materials, their change in length is proportional to the square of the applied voltage and on the same order as PZTs. Unlike piezoelectric devices, PMN ceramics are not *poled*. Positive or negative voltage

excursions result in an elongation in the direction of the applied field, regardless of its polarity. Because the PMN is unpoled, it is an inherently more stable device without the long term creep associated with PZT. The creep, which can range up to 15% for PZT devices is reduced to just 3% as shown in Figure 25.

PMN materials also have better hysteresis characteristics than conventional PZT elements. While piezoelectric devices exhibit hysteresis of 12 to 15%, PMN hysteresis is only 6% (Figure 26).

	Stepper Motor	DC Motor
Controller Electronics & Software	Easier—can do open-loop control with straight-forward microprocessor implementation	More complex—feedback from motor encoder/tachometer requires analog to digital conversion
Driver Electronics	More complex—require commutation circuitry	Easier—windings are self commutating
Maintenance	No brushes to worry about	Brushes can wear requiring periodic maintenance after a large number of cycles
Motor Heating	Higher due to continuous current in windings	Lower motor heating with no motor current at target position (with integral gain, K_i , equal to zero)
Torque vs. Speed	Full torque at very low speeds dropping off quickly as speed increases	Flatter torque curve over the speed range provides higher torque at higher speeds
Dynamic Range	Lower for velocity and acceleration	Higher for velocity and acceleration
Resonance	Inherent vibration at certain lower frequencies can be a problem when accelerating to a higher speed. Ministeping reduces this problem	Smooth quiet operation across speed range
Servo Tuning	None required	PID tuning can be tricky if the system dynamics are not understood
Reaching Final Position	Reaches final position without overshoot. Very stable holding a position due to natural detent forces. Open-loop may not reach final position if load or speed capacities are exceeded	Reaches final position with closed-loop error correction. Corrects for trajectory errors also. Possible overshoot, hunting, or steady-state error if PID tuning is inadequate

Figure 24 — Advantages and disadvantages of stepper and brushed DC motors.

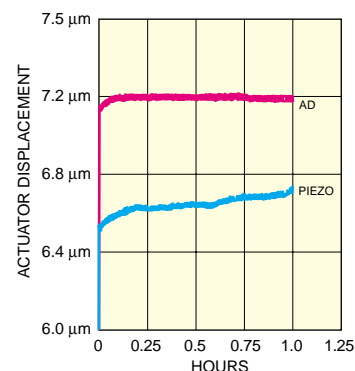

Figure 25 — Comparing actuator creep—electrostrictive actuators are superior to conventional PZTs when trying to maintain position over time. The figure shows the results after one hour with a voltage step applied at time-zero.

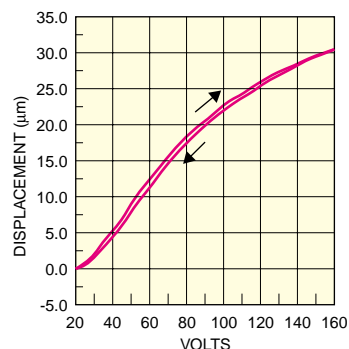

Figure 26 — Electrostrictive actuators have very little hysteresis.

Vacuum Compatibility

Stages used in a vacuum of 10^{-6} torr or better must be specially prepared for that environment. Many of the materials used in standard translation stages will outgas in high vacuum, resulting in a “virtual” leak which limits the ability to maintain adequate vacuum.

Procedures used at Newport to specially prepare products for use in vacuum environments ensure that our products will function as designed at pressure levels down to 10^{-6} torr and at the same time not release unacceptable quantities of contaminants into the vacuum environment. More information than just the operating pressure is required for proper preparation. Acceptable levels of outgassing, mass loss and volatile condensable materials can vary with the application, pumping capacity, temperature, etc.

Material issues that must be addressed include the selection of acceptable metals, ceramics, coatings, lubricants, adhesives, rubbers, plastics and electrical components, etc. For example, highly porous anodized aluminum surfaces trap large amounts of air molecules, resulting in significant outgassing. For this reason, aluminum used in

high-vacuum applications is unanodized. Motors must also be specially prepared for vacuum operation.

Machining practices must avoid creating surfaces conducive to trapping gases and other foreign materials that could be released in vacuum conditions. Care must also be taken to ensure that gasses are not trapped in assembly cavities.

In addition to material selection and manufacturing practices, special cleaning, handling, assembly and packaging practices must be followed. These functions are carried out in a clean environment to minimize the possibility of airborne contaminants becoming attached to the components. Newport does not perform bakeout at an elevated temperature.

Performance specifications for products used in a vacuum environment may vary from non-vacuum use. For example, because heat cannot be as readily dissipated, motor duty cycle must be reduced which in turn may limit the maximum achievable speed. If your application requires vacuum preparation, please contact our Applications Engineering Department to discuss your specific application needs.

Cleanroom Compatibility

Newport has facilities to properly prepare products for cleanroom applications. While many of the techniques, practices, procedures and material requirements for cleanroom applications are similar to

those for vacuum preparation, each application has its own unique requirements. Please contact our Applications Engineering Department to discuss your specific application needs.

Feedback Devices

A feedback device's basic function is to transform a physical parameter into an electrical signal for use by a motion controller. Common feed-

back devices are encoders for position feedback, tachometers for velocity feedback, and accelerometers for acceleration feedback.

Indirect vs. Direct Metrology

The location in the motion system from which the feedback device performs its measurements directly affects the quality of the data fed back to the controller. The closer the feedback device is to the parameter being controlled, the more effective it will be in helping the controller achieve the desired result. When controlling position, for example, measuring the linear position of the stage carriage directly provides higher quality feedback than measuring the angular position of the leadscrew and inferring carriage position through knowledge of the drivetrain architecture between the encoder and the carriage (Figure 31). The former is known as *direct output metrology* and avoids the drivetrain induced errors like backlash, hysteresis and windup that can affect the latter, indirect measurement.

Rotary Encoder

A rotary encoder can differentiate a number of discrete positions per

revolution. This number is called its *points per revolution* and is analogous to the steps per revolution of a stepper motor. A DC motor with a 2000 points per revolution encoder is like a stepping motor with 200 steps per revolution when driven by a ministep driver. The speed of an encoder is in units of counts-per-second. Linear and rotary stages and actuators incorporating indirect metrology use rotary encoders measuring the motor shaft or leadscrew angle to report position. Conversely, rotary encoders can also be used on rotation stages for direct output metrology.

Linear Encoder

A linear encoder is used when direct verification of the output accuracy, resolution and repeatability of the positioning system is desired. These encoders can be used as direct output metrology devices to overcome many of the inaccuracies present in mechanical stages due to backlash, hysteresis and leadscrew error.

Optical Encoders

Although there are various kinds of digital encoders, the most common is the optical encoder. Rotary and linear optical encoders are used frequently for motion and position sensing.

A disc or a plate containing opaque and transparent segments passes between a light source (such as an LED) and detector to interrupt a light beam (Figures 27 & 28). The electronic signals that are generated are then fed into the controller where position and velocity information is calculated based upon the signals received.

Optical encoders can be further subdivided into *absolute* and *incremental* encoders.

Absolute Encoders

Absolute encoders contain multiple detectors and up to 20 tracks of segment patterns. For each encoder position, there is a different binary output so that shaft position is absolutely determined. With absolute encoders, the position information is available even if the encoder is turned off and on again.

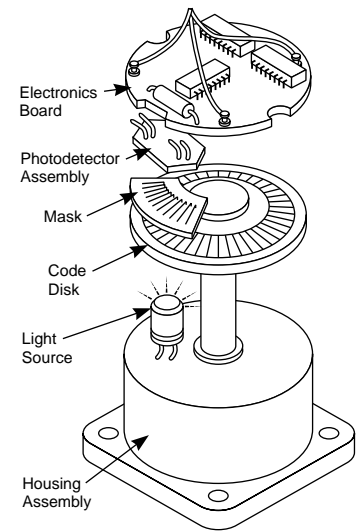

Figure 27 — Optical rotary encoders commonly use a stationary mask between the code wheel and the detector.

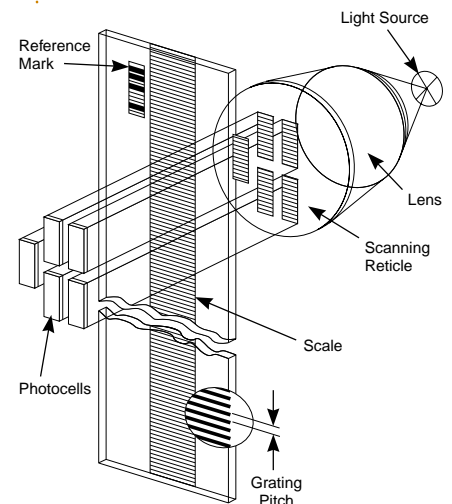

Figure 28 — Optical linear encoders direct light through a glass scale with an accurately etched grating to photocells on the opposite side.

Incremental Encoders

When lower cost is important, or when only relative information is needed, incremental encoders are preferred. Their output consists of electronic signals corresponding to an increment of linear or rotational movement.

Many incremental encoders also have a feature called the index pulse. An index pulse occurs once per encoder revolution in rotary encoders (Figure 29). It is used to establish an absolute mechanical reference position within one encoder count of the 360° encoder rotation. The index signal can be used to do several tasks in the system. It can be used to reset or preset the position counter and/or generate an interrupt signal to the system controller.

Quadrature Encoders

Quadrature encoders are a particular kind of incremental encoder with of at least two output signals, commonly called channel A and channel B. As seen in Figure 30, channel B is offset 90 degrees from channel A. The addition of a second channel provides direction information in the feedback signal. The ability to detect direction is critical if encoder rotation stops on a pulse edge. Without the ability to decode direction, the counter may count each transition

through the rising edge of the signal and lose position.

Another benefit of the quadrature signal scheme is the ability to electronically multiply the counts during one encoder cycle. In the times-1 mode, all counts are generated on the rising edges of channel A. In the times-2 mode, both the rising and falling edges of channel A are used to generate counts. In the times-4 mode, the rising and falling edges of channel A and channel B are used to generate counts. This increases the resolution by a factor of four. For encoders with sine wave output, the channels may be interpolated for very high resolution.

Tachometers

For applications requiring velocity regulation, speed can be either measured directly or derived from encoder supplied position information. For higher quality speed control, a tachometer is used which produces a voltage or current level proportional to the speed of the motor (Figure 31). Tachometer feedback can change instantaneously with speed change allowing faster correction and tighter regulation from a controller.

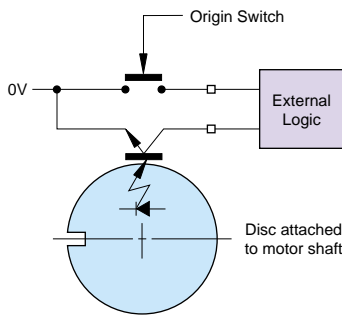

Figure 29 — To get submicron repeatability using an index pulse from an encoder, homing should always be approached from the same direction.

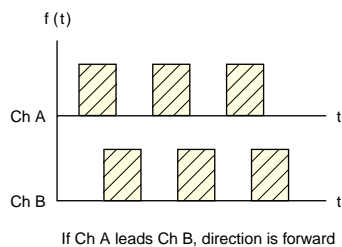

Figure 30 — Quadrature encoder output provides direction as well as position feedback.

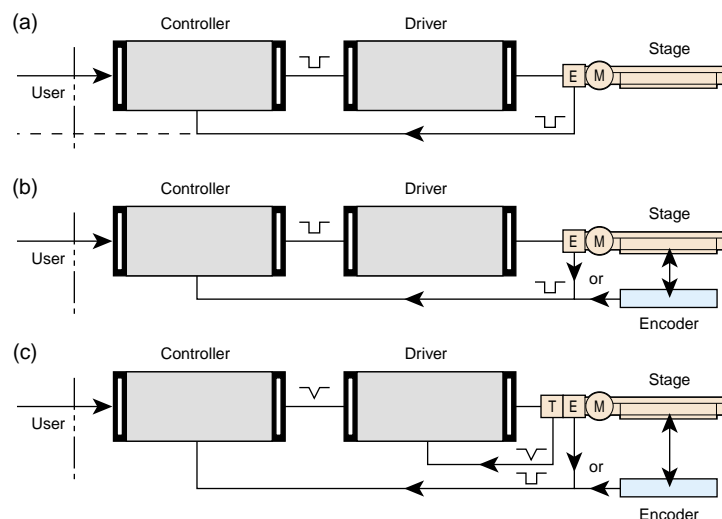

Figure 31 — Closed-loop systems. a) Using indirect metrology rotary encoder b) Using direct metrology linear encoder c) Using encoder for position feedback and tachometer for velocity control.

An origin switch is a device which defines a repeatable reference point. The switch may be mechanical, such as an on/off switch or it may be an optical device such as the index pulse (top zero) of optical encoders (Figure 29).

Limit switches are used to prevent motion from proceeding beyond a defined point. They are usually located at the ends of stage travel immediately before the stage's hard travel stops. They can be mechanical or optical and are designed to cut

motor power when a limit is encountered. Limit switches are most often associated with linear stages but rotary stages can also have limits to avoid problems like cable wind-up.

Mechanically actuated micro-switches are often used to cut motor power and prevent over-travel. The repeatability of mechanical switches is limited by their hysteresis and susceptibility to wear.

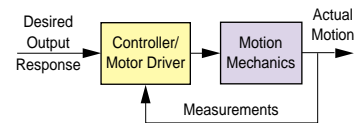

Figure 32 — Basic feedback control system.

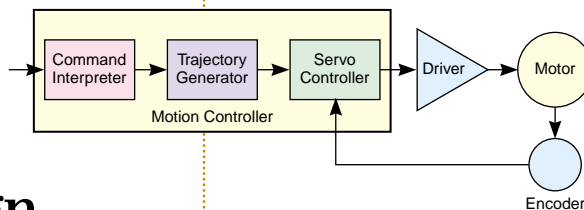

Figure 33 — Functional block diagram of controller operations.

Motion Electronics Design

Controllers

A controller is a device in a motion system that generates electronic signals instructing the motion mechanics to move or stop. If a feedback system exists, then signals measuring the actual motion output are returned to the controller. The controller compares the actual to desired output and generates an error signal upon which corrective action is taken (Figure 32).

The controller sends signals to the motor driver to control motion within the system. A controller can have various features such as data communications, input/output lines, memory for storing motion programs, and encoder feedback processing for closed-loop positioning (Figure 33).

Although a displacement can take several seconds, the controller has to work at higher speeds to make calculations and output updated motion commands. The time needed for these actions to take place is called the *sampling time*.

Centralized versus Distributed Motion Processing

Controllers may be designed such that a single microprocessor controls motion on all axes. Alternatively, the controller may use a distributed configuration where a central microprocessor coordinates dedicated special-purpose motion control chips on each axis (Figures 34 & 35).

Digital Signal Processor

Digital Signal Processors (DSPs) are special chips manufactured to address the increased speed requirements in calculating advanced control algorithms. When these operations are performed on an ordinary processor, they can consume too much time to provide high-speed control.

DSPs are often built using an architecture that allows instructions and data to move in parallel instead of sequentially. They often carry high speed hardware multipliers and fast on-chip memories that eliminate many delays associated with information transfer to and from the chip.

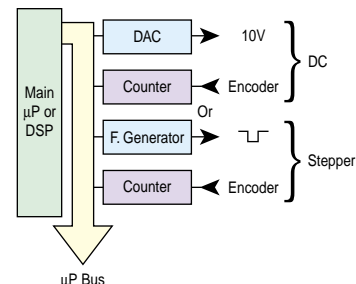

Figure 34 — With centralized motion processing, all axes are controlled by a single microprocessor.

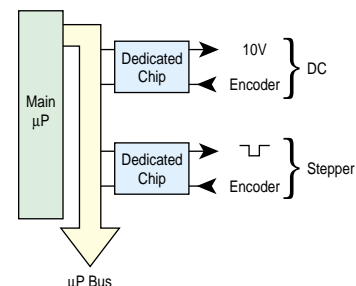

Figure 35 — Distributed motion processing provides dedicated motion controller chips for each axis coordinated by a central CPU.

A motor driver receives input signals from a controller and converts them to power to drive a motor. With stepper drivers, the user has the option of selecting from among full, half, or microstep resolutions and the desired output power of the device.

Stepper Motor Driver

Full Step

A full step driver operates a stepper motor in a detent-to-detent stepping mode. When power is removed, the stepper motor will not move from its current position due to its inherent holding or detent torque.

Half Step

A half step driver operates a stepper motor by positioning the armature halfway between actual detent positions. This provides higher resolution and somewhat smoother motion over the motor's operating speed range. However, if power is removed, the stepper motor will move from its current half step position to a physical detent position.

Microstep/Ministep

A microstep driver will position a stepper motor armature a defined fraction of a full step between the actual detent positions. In this catalog, microstep is used to describe $\frac{1}{100}$ of a full step and ministep is $\frac{1}{10}$ of a full step. Mini- and microstepping are used for greater resolution and to avoid resonance problems and skipping steps in the motor over the speed range of the stage. Once again, if power is removed, the motor will move from its current position to a true detent position.

High-Voltage Chopper Technology

A simple four-phase driver is fine for basic, low performance applications. But, if high speeds are required, quickly switching the current with inductive loads becomes a problem. When voltage is applied to a winding, the current (and therefore, the torque) approaches its nominal value exponentially (Figure 36). When the pulse rate is fast, the current does not have time to reach the desired value before it is again turned off so the total torque generated is only a fraction of nominal.

The time required for the current to reach its nominal value depends on three factors: the motor winding's inductance, its resistance and the voltage applied.

The inductance cannot be reduced, but the voltage can be temporarily increased to bring the current to its desired level faster. The most widely used technique is a high voltage chopper.

If, for instance, a stepper motor requiring only 3 V to reach the nominal current is connected momentarily to 30 V, it will reach the same current in only $\frac{1}{10}$ the time.

Once the desired current value is reached, a chopper circuit activates to keep the current close to the nominal value (Figure 37).

DC Motor Drivers

Drivers for DC motors convert a small voltage signal from the controller (usually ± 10 V) into a usable current to drive the motor.

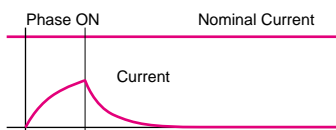

Figure 36 — Exponential current build-up in the motor is too slow for high speed applications.

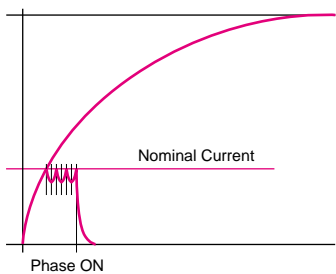

Figure 37 — A high voltage chopper helps a stepper motor reach full current faster enabling higher speeds.

Control Theory Terminology

Common motion systems use three types of control methods. They are *position* control, *velocity* control and *torque* control.

The majority of Newport's motion systems use position control. This type of control moves the load from one known fixed position to another known fixed position. Feedback, or closed-loop positioning, is important for precise positioning.

Velocity control moves the load continuously for a certain time interval or moves the load from one place to another at a prescribed velocity. Newport's systems use both encoder and tachometer feedback to regulate velocity.

Torque control measures the current applied to a motor with a known torque coefficient in order to develop a known constant torque. Newport's motion systems do not employ this method of control.

Following Error

The instantaneous difference between actual position as reported by the position feedback device and the ideal position, as commanded by the controller.

Settling Time

The amount of time elapsed between when a stage first reaches a commanded position and when it maintains the commanded position to within an acceptable pre-defined error value (Figure 38).

Overshoot

The amount of over-correction in an under-damped control system (Figure 39).

Steady-State Error

The difference between actual and commanded position after the controller has finished applying corrections (Figure 39).

Vibration

When the operating speed approaches a natural frequency of the mechanical system, structural vibrations, or *ringing*, can be induced. Ringing can also occur in a system following a sudden change in velocity or position. This oscillation will lessen the effective torque and may result in loss of synchronization between the motor and controller.

Settling times and vibrations can best be dealt with by damping motor oscillations through mechanical means such as friction or a viscous damper. When operating a stepper system, some additional methods that can change resonance vibration frequencies are:

- half stepping or microstepping the motor
- changing the system inertia
- accelerating through the resonance speed ranges
- modifying drivetrain torsional stiffness

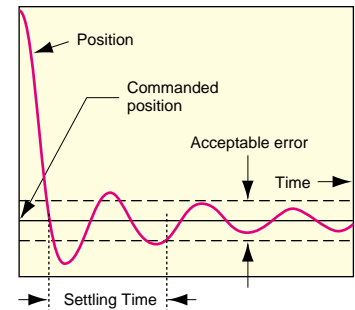

Figure 38 – How settling time is defined.

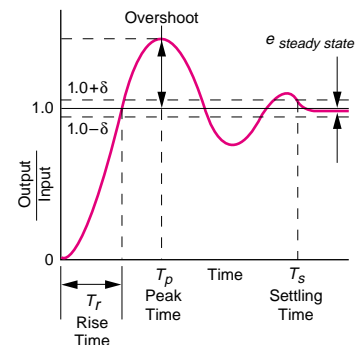

Figure 39 — Response for a system using only proportional control leads to overshoot and non-zero steady-state errors.

Velocity Profiles

In order to achieve smooth high-speed motion without over-taxing the motor, the controller must direct the motor driver to change velocity judiciously to achieve optimum results. This is accomplished using shaped velocity profiles to limit the accelerations and decelerations required.

Trapezoidal Profile

The trapezoidal profile changes velocity in a linear fashion until the target velocity is reached. When decelerating, the velocity again changes in a linear manner until it reaches zero velocity. Graphing velocity versus time results in a trapezoidal

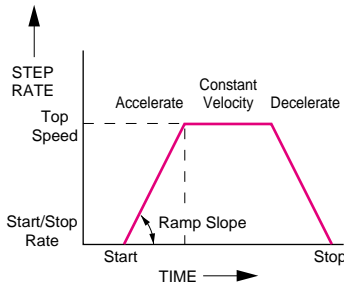

Figure 40 — Trapezoidal motion profiles are required to obtain higher speeds without skipping steps or stalling.

plot (Figure 40). Advanced controllers allow user modification of the acceleration/deceleration with more advanced controllers allowing individual settings for acceleration and deceleration.

S Curve Profile

A trapezoidal velocity profile is adequate for most applications. Its only disadvantage is that it may

cause some system disturbances at the “corners” that translate in small vibrations which extend the settling time. For demanding applications sensitive to this phenomenon, the velocity profile can be modified to have an S shape during the acceleration and deceleration periods. This minimizes the vibrations caused in a mechanical system by a moving mass.

Control Loops

Open-Loop Control

Open-loop refers to a control technique which does not measure and act upon the output of the system. Most piezoelectric systems and inexpensive micrometer-replacement actuators are open-loop devices.

Open-loop positioners are useful when remote control is desired for improved accessibility or to avoid disturbing critical components by touching them.

Stepper and ministepper motors are also often used open-loop. The count of pulses is a good indicator of position, but can be unpredictable unless loads, accelerations and velocities are well known. Skipped or extra steps are frequent problems if the system is not properly designed.

Open-loop motion control has become very popular. Advances in ministepping technology and incorporation of viscous motor-damping mechanisms have greatly improved the positioning dependability and reduced vibration levels of today's highest quality stepper devices.

Open-loop is by no means a synonym for crude. Very fine incremental motions can be achieved even by inexpensive open-loop devices. Nanometer-scale incremental motions are achievable by open-loop piezo- and electrostrictive-type devices.

Open-loop systems infer the approximate position of a motion device without using an encoder. In the case of a piezo device, the applied voltage is an indicator of position. However, the relationship is imprecise due to hysteresis and non-linearities inherent in commonplace piezo materials. More recently-developed electrostrictive materials operate in a similar manner with greatly reduced hysteresis.

Closed-Loop Control

Closed-loop refers to a control technique which measures the output of the system compared to the desired input and takes corrective action to achieve the desired result. Electronic feedback mechanisms in closed-loop systems enhance the ability to correctly place and move loads.

Closed-Loop Control Techniques

Depending upon how the feedback signals are processed by the controller, different levels of performance can be achieved. The simplest type of feedback is called *proportional* control.

Other types are called *derivative* and *integral* control. Combining all three techniques into what's called PID control provides the best results.

Proportional Control

A control technique which multiplies the error signal (the difference between actual and desired position) by a user-specified gain factor K_p and uses it as a corrective signal to the motion system. The effective result is to exaggerate the error and react immediately to correct it.

Changes in position generally occur during commanded acceleration, deceleration, and in moves where velocity changes occur in the system dynamics during motion. As K_p is increased the error is more quickly corrected. However, if K_p becomes too large, the mechanical system will begin to overshoot, and at some point, it may begin to oscillate, becoming unstable if it has insufficient damping.

K_p cannot completely eliminate errors since as the following error, e , approaches zero, the proportional correction element, $K_p e$, disappears. This results in some amount of steady-state error.

Integral Control

A control technique which accumulates the error signal over time, multiplies the sum by a user specified gain factor K_i and uses the result as a corrective signal to the motion system. Since this technique also acts upon past errors, the correction factor does not go to zero as the following error, e , approaches zero allowing steady-state errors to be eliminated.

The integral gain has an important negative side effect. It is a destabilizing factor for the stability of the control loop. Large values or used without proper damping could cause severe system oscillations.

Derivative Control

A control technique which multiplies the rate of change of the following error signal by a user specified gain K_d and uses the result as a corrective signal to the motion system. Since

this type of control acts to stabilize the transient response of a system, it may be thought of as electronic damping.

Increasing the value of K_d , increases the stability of the system. The steady-state error, however, is unaffected since the derivative of the steady-state error is zero.

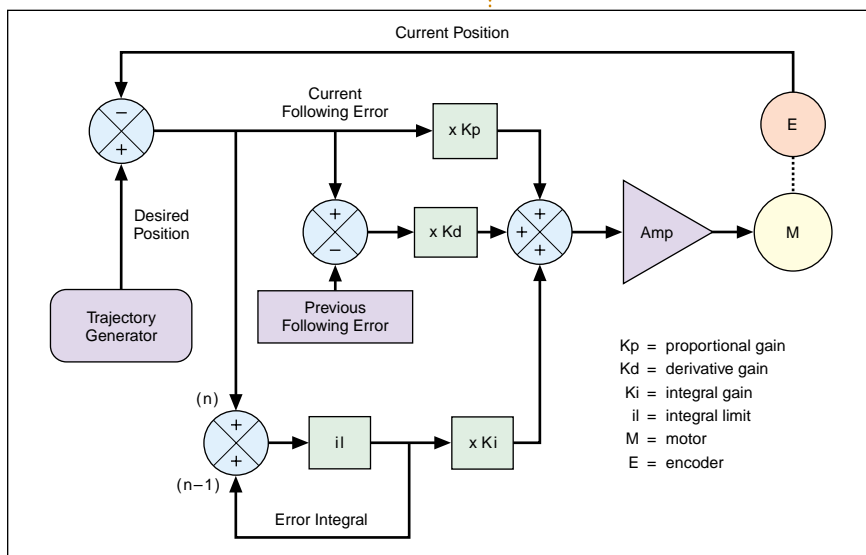

Figure 41 — PID control implemented using position feedback.

PID Control

The combination of *proportional plus integral plus derivative* control. For motion systems, the PID loop has become a very popular control algorithm (Figure 41). The feedback elements are interactive and knowing how they interact is essential for *tuning* a motion system. Optimum system performance requires that the coefficients, K_p , K_i , and K_d , be tuned for a given combination of motion mechanics and payload inertias.

Feed Forward Loops

When using a PID control algorithm, an error between the desired and actual positions must exist in order to generate a corrective input. The implication of this is that there will always be some non-zero *following error*. The goal when using a feed forward loop is to minimize following error.

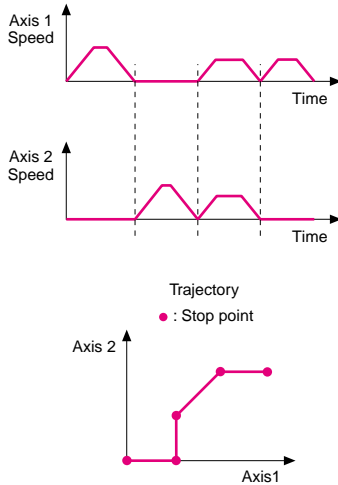

Figure 43 — With synchronized motion, multiple axes may or may not move together.

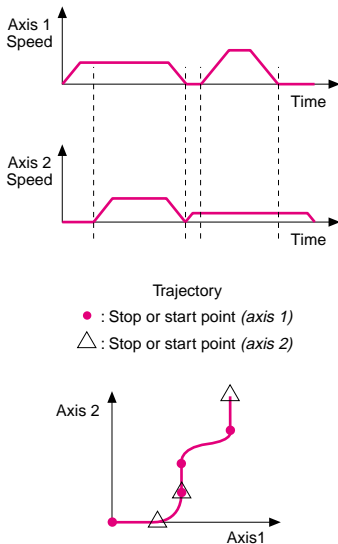

Figure 44 — With non-interpolated motion several axes can move simultaneously, but are not coordinated.

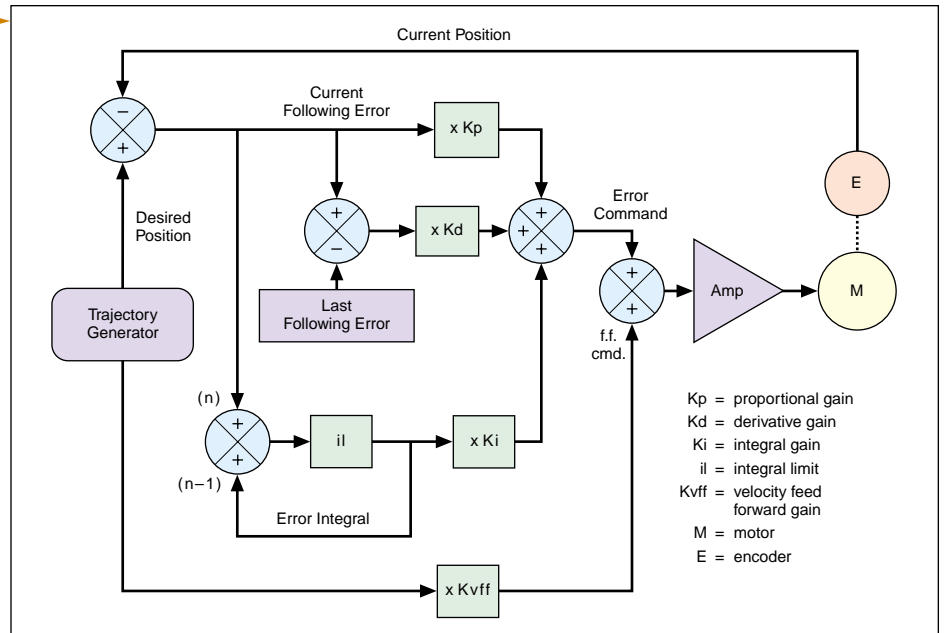

Figure 42 — Adding a feed forward loop to the PID controller reduces following error and improves overall system performance.

The concept in using a feed forward loop is to predict how the system will function in future updates and to make corrections now based on those estimates (Figure 42).

The corrections are generally implemented by multiplying the desired velocity with the velocity feed-forward gain factor K_{vff} . The same technique can be used to apply an acceleration

feed-forward correction signal. This correction is being used to reduce the average following error during the acceleration and deceleration periods. Combining feed forward techniques with PID allows the PID loop to correct only for the residual error left by the feed forward loop, thereby improving overall system response.

Positioning Trajectory Options

Motion Without Interpolation

There are three types of non-interpolated motion: *single-axis*, *simultaneous*, and *synchronized* motion.

Simultaneous and synchronized motion are both multi-axis (Figure 43). The difference between them is that simultaneous motion is unsynchronized (Figure 44).

Motion with Interpolation

When the controlled load must follow a particular path to get from its starting point to its stopping point, the coordination of axis movements is said to be interpolated. There are two types of interpolation, *linear* and *circular*.

Linear Interpolation

Linear interpolation is required for multi-axis motion from one point to another in a straight line. The controller determines the speeds on each axis so that the movements are coordinated. True linear interpolation requires the ability to modify acceleration. Some controllers approximate linear interpolation using pre-calculated acceleration profiles (Figure 45).

Circular Interpolation

Circular interpolation is the ability to move the payload around a circular trajectory. It requires the controller to modify acceleration on the fly (Figures 46 & 47).

Contouring

With contouring, the controller changes the speeds on the different axes so that the trajectories pass smoothly through a set of pre-

defined points. The speed is defined along the trajectory and can be constant, except during starting and stopping (Figure 48).

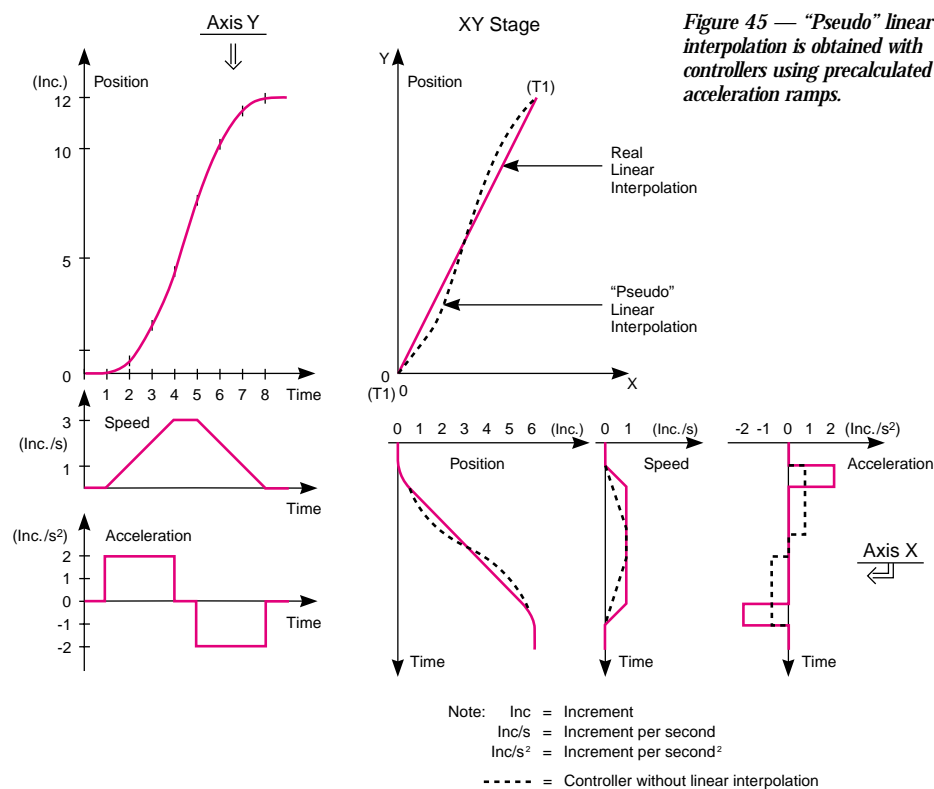

Figure 45 — “Pseudo” linear interpolation is obtained with controllers using precalculated acceleration ramps.

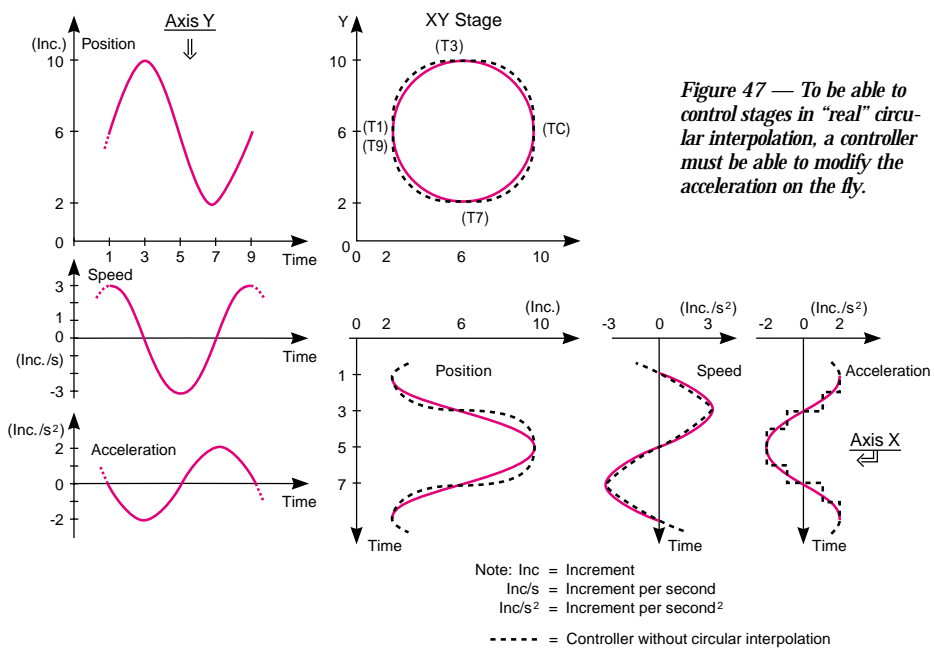

Figure 47 — To be able to control stages in “real” circular interpolation, a controller must be able to modify the acceleration on the fly.

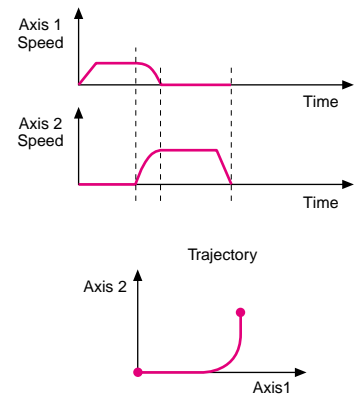

Figure 46 — Simple circular interpolation.

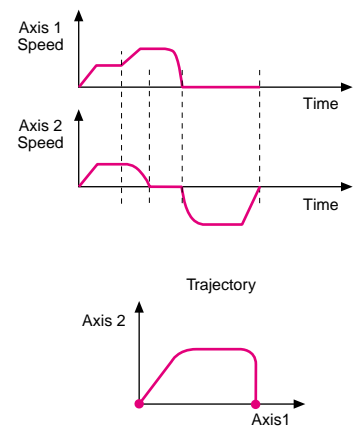

Figure 48 — Applications such as laser writing require unusual trajectories executed at constant speed.

Servo Tuning Principles

Servo tuning sets the K_p , K_i and K_d and the feed forward parameters of the digital PID algorithm, also called the *PID filter*.

Always start the tuning process using the default values supplied with the controller. These values are usually very conservative, favoring safe, oscillation-free operation for a tighter,

more responsive system that minimizes following error. To achieve the best dynamic performance possible, the system must be tuned for the specific application. Load, acceleration, stage orientation and performance requirements all affect how the servo loop should be tuned for best results.

Before you start
Proper tuning requires the motor driver's signal gain, tachometer gain and DC offset on each axis to be properly adjusted. Please consult our technical staff.

Tuning Procedures

As a rule of thumb for tuning systems:

- Always start tuning with proportional gain K_p to get adequate response speed
- Next, increase the value for K_d to decrease the overshoot and stabilize the system
- Finally, increase the value for K_i to eliminate steady-state error
- To avoid stability problems, never use K_p and K_i without K_d

Servo tuning is usually performed to achieve better motion performance (such as reducing the following error

statically and/or dynamically) or because the system is malfunctioning (oscillating and /or shutting off due to excessive following error).

Acceleration plays a significant role in the magnitudes of the following error and the overshoot, especially at start and stop. Asking the controller to change the velocity instantaneously amounts to an infinite acceleration which, since it is physically impossible, causes large following errors and overshoot. Use the smallest acceleration the application can tolerate to reduce overshoot and make tuning the PID filter easier.

Stabilizing Axis Oscillation

If an axis oscillates, this indicates that the gain K_p may be too large. Start by reducing the proportional gain factor K_p by one order of magnitude (e.g., 0.2 to 0.02) and making K_i and K_d equal to zero.

If the oscillation does not stop, reduce K_p again.

When the axis *stops* oscillating, the system response is probably very soft. The following error may be quite large during motion and non-zero at stop. You should continue tuning the PID with the steps described in the next paragraph.

Improving Stable Performance

If the system is stable and you want to improve the performance, start with the current parameters. The goal is to reduce the following error during motion and to eliminate it at stop.

Depending on the performance starting point and the desired outcome, here are some guidelines for further tuning.

Following Error Too Large

This is a case of a soft loop. It is especially common if you just performed the steps described under axis oscillations. The proportional gain K_p is probably too low and K_i and K_d are zero.

Start by increasing K_p by a factor of 1.5 to 2. Continue this operation while monitoring the following error until it starts to exhibit excessive ringing characteristics (more than 3 cycles after stop). To reduce the ringing, add some damping by increasing the K_d parameter.

Start with a K_d value one order of magnitude smaller than K_p . Increase it by a factor of 2 while monitoring the following error. As K_d is increased, the overshoot and the ringing will decrease almost to zero.

NOTE

Remember that if the acceleration is set too high, the overshoot cannot be completely eliminated with K_d .

If K_d is further increased, at some point the oscillation will reappear, usually at a higher frequency. Avoid this by keeping K_d at a high enough value, but not so high as to reintroduce oscillations.

Next, add more gain. Increase the K_p value by 50% at a time until signs of excessive ringing appear again.

Alternately increase K_d and K_p until K_d cannot eliminate the overshoot and ringing at stop. This indicates K_p is larger than its optimal value and should be reduced.

Ultimately, optimal values for K_p and K_d depend on the stiffness of the loop and how much ringing the application can tolerate.

Errors After Stop

If you are satisfied with the dynamic response of the PID loop but the motion device does not always stop

accurately, modify the integral gain factor K_i . As described before, this term of the PID reduces the following error to near zero. Unfortunately, it can also contribute to oscillation and overshoot. Always change this parameter carefully and in conjunction with K_d .

Start, if possible with a value for K_i that is at least two orders of magnitude smaller than K_p . Increase its value by 50% at a time and monitor the overshoot and the final position at stop.

If intolerable overshoot develops, increase the K_d factor. Continue alternately increasing K_i and K_d until an acceptable loop response is obtained. If oscillation develops, immediately reduce the K_i .

Remember that any finite value for K_i will eventually reduce the error at stop. It is simply a matter of how much time is acceptable for the application. In most cases it is preferable to wait a few extra milliseconds to stop in position rather than have overshoot or run the risk of oscillations.

Following Error During Motion

This is caused by a K_i value that is too low. Follow the steps in the previous paragraph, keeping in mind that it is desirable to increase the integral gain factor as little as possible.

Points to Remember

- Use the lowest acceleration the application can tolerate. Smaller acceleration generates less overshoot.
- Use the default values provided with the system for all standard motion devices as a starting point.
- Use the minimum value for K_i that gives acceptable performance. The integral gain factor can cause overshoot and oscillations.