

System V IPC (Cont'd)

EXAMPLE:

Single producer, multiple consumer, multiple flavor problem

Header file:

```
#include <sys/types.h>
#include <sys/ipc.h>
#include <sys/sem.h>
#include <sys/shm.h>

#define SEMKEY (key_t)5763
#define MEMKEY (key_t)5763
#define NUMFLAVORS 4
#define NUMSLOTS 50
#define NUMSEMIDS 3
#define PROD 0
#define CONSUMER 1
#define OUTPTR 2

struct donut_ring{
    int flavor[NUMFLAVORS][NUMSLOTS];
    int outptr[NUMFLAVORS];
};

void handler();
void p();
void v();
void semsetall();
```

System V IPC (Cont'd)

EXAMPLE:

Single producer, multiple consumer, multiple flavor problem

The utility file:

```
#include "donuts.h"

void    p(int semidgroup, int donut_type)
{
    struct sembuf semopbuf;

    semopbuf.sem_num=donut_type;
    semopbuf.sem_op=(-1);
    semopbuf.sem_flg=0;

    if(semop(semidgroup, &semopbuf,1) == -1){
        perror("p operation failed: ");
        exit(2);
    }
}

void    v(int semidgroup, int donut_type)
{
    struct sembuf semopbuf;

    semopbuf.sem_num=donut_type;
    semopbuf.sem_op=(+1);
    semopbuf.sem_flg=0;

    if(semop(semidgroup, &semopbuf,1) == -1){
        perror("p operation failed: ");
        exit(2);
    }
}
```

System V IPC (Cont'd)

EXAMPLE:

Single producer, multiple consumer, multiple flavor problem

The utility file cont'd:

```
void    semsetall(int semgroup, int number_in_group,
                int set_all_value){
    int    i,j,k;

    for(i=0; i<number_in_group; i++){
        if(semctl(semgroup, i, SETVAL, set_all_value) == -1){
            perror("semset failed");
            handler(-3);
            exit(3);
        }
    }
}

void    handler(int sig){
    int    i,j,k;

    printf("In signal handler with signal # %d\n",sig);
    if(shmctl(shmid, IPC_RMID) == -1){
        perror("handler failed shm RMID: ");
        exit(4);
    }
    for(i=0; i<NUMSEMIDS; i++){
        if(semctl(semid[i], 0, IPC_RMID) == -1){
            perror("handler failed sem RMID: ");
            exit(4);
        }
    }
}
```

System V IPC (Cont'd)

EXAMPLE:

Single producer, multiple consumer, multiple flavor problem

The producer:

```
#include "donuts.h"

int main(int argc, char * argv[]){
    int    cntr, *addr1, *addr2;
    struct sigaction  new;
    sigset_t  mask_sigs;
    int sigs[] = {SIGHUP,SIGINT,SIGQUIT, SIGPIPE
                 SIGTERM, SIGBUS, SIGSEGV, SIGFPE};
    int    in_ptr[NUMFLAVORS];
    int    serial[NUMFLAVORS];
    int    i,j,k, nsigs;
    struct donut_ring *shared_ring;

    nsigs = sizeof(sigs)/sizeof(int)
    sigemptyset(&mask_sigs);
    for(i=0; i< nsigs; i++)
        sigaddset(&mask_sigs, sigs[i]);
    for(i=0; i< nsigs; i++){
        new.sa_handler = sig_handler;
        new.sa_mask = mask_sigs;
        new.sa_flags = SA_RESTART;
        if(sigaction(sigs[i], &new, NULL) == -1){
            perror("can't set signals: ");
            exit(1);
        }
    }
}
```

System V IPC (Cont'd)

EXAMPLE:

Single producer, multiple consumer, multiple flavor problem

The producer cont'd:

```
for(i=0; i<NUMFLAVORS; i++){
    in_ptr[i]=0;
    serial[i]=0;
}

if((shmid=shmget(MEMKEY, sizeof(struct donut_ring),
                IPC_CREAT | 0666)) == -1){
    perror("shared get failed: ");
    exit(1);
}

if((shared_ring=(struct donut_ring *)shmat(shmid,0,0))== -1){
    perror("shared attach failed: ");
    handler(-1);
}

for(i=0; i<NUMSEMIDS; i++)
    if((semid[i]=semget(SEMKEY+i, NUMFLAVORS,
                       IPC_CREAT | 0666)) == -1){
        perror("semaphore allocation failed: ");
        handler(-1);
    }

srandom((time((time_t *)0) + getpid()));
semsetall(semid[PROD], NUMFLAVORS, NUMSLOTS);
semsetall(semid[CONSUMER], NUMFLAVORS, 0);
semsetall(semid[OUTPTR], NUMFLAVORS, 1);
```

System V IPC (Cont'd)

EXAMPLE:

Single producer, multiple consumer, multiple flavor problem

The producer cont'd:

```
while(1){
    j=random() & 3;
    p(semid[PROD], j);
    shared_ring->flavor[j][in_ptr[j]]=serial[j];
    in_ptr[j] = (in_ptr[j]+1) % NUMSLOTS;
    serial[j]++;
    printf("prod type %d serial %d\n",j,serial[j]-1);
    v(semid[CONSUMER], j);
}
}
```

System V IPC (Cont'd)

EXAMPLE:

Single producer, multiple consumer, multiple flavor problem

The consumer:

```
#include "donuts.h"

int main(int argc, char * argv[]){
    int    i,j,k,donut;
    struct donut_ring *shared_ring;

    if((shmid=shmget(MEMKEY, sizeof(struct donut_ring),
                    0)) == -1){
        perror("shared get failed: ");
        exit(1);
    }

    if((shared_ring=(struct donut_ring *)shmat(shmid,0,0))== -1){
        perror("shared attach failed: ");
        exit(1);
    }

    for(i=0; i<NUMSEMIDS; i++){
        if((semid[i]=semget(SEMKEY+i, NUMFLAVORS,
                            0)) == -1){
            perror("semaphore allocation failed: ");
            exit(1);
        }
    }
}
```

System V IPC (Cont'd)

EXAMPLE:

Single producer, multiple consumer, multiple flavor problem

The consumer cont'd:

```
    srand(time((time_t)0) + getpid());

    for(i=0; i<10; i++){
        for(k=0; k<12; k++){
            j=random() & 3;
            printf("in consumer with rand %d\n",j);
            p(semid[CONSUMER], j);
            p(semid[OUTPTR], j);
            donut=shared_ring->flavor[j][shared_ring->outptr[j]];
            shared_ring->outptr[j] =
                (shared_ring->outptr[j]+1) % NUMSLOTS;
            v(semid[PROD], j);
            v(semid[OUTPTR], j);
        }
        printf("dozen number %d completed \n\n",i);
    }
}
```

Interhost IPC With Sockets

The UNIX socket facility provides a full duplex communication abstraction for process to process communication within and across hosts:

- Sockets support both virtual circuit connection based service and unconnected datagram service
- While sockets provide an API to a network environment and have been implemented over several different lower layer protocols, in the UNIX world they are most commonly found on top of the transport protocols TCP and UDP and the network protocol of the internet, IP
- The most common applications built over sockets include packages such as ftp, telnet, smtp, and the remote commands from BSD. These all use a client- server model with a connection based structure

The Network Landscape

Application	ftp	NFS	NIS	tftp
Presentation	mail	XDR		talk
Session	rcp	RPC		named
	rlogin			time
	telnet			rwho
Transport	TCP		UDP	
Network	IP			
Data Link	Ethernet	X.25	...	
Physical	Ethernet	Sync	...	

Socket Interhost IPC with TCP/IP

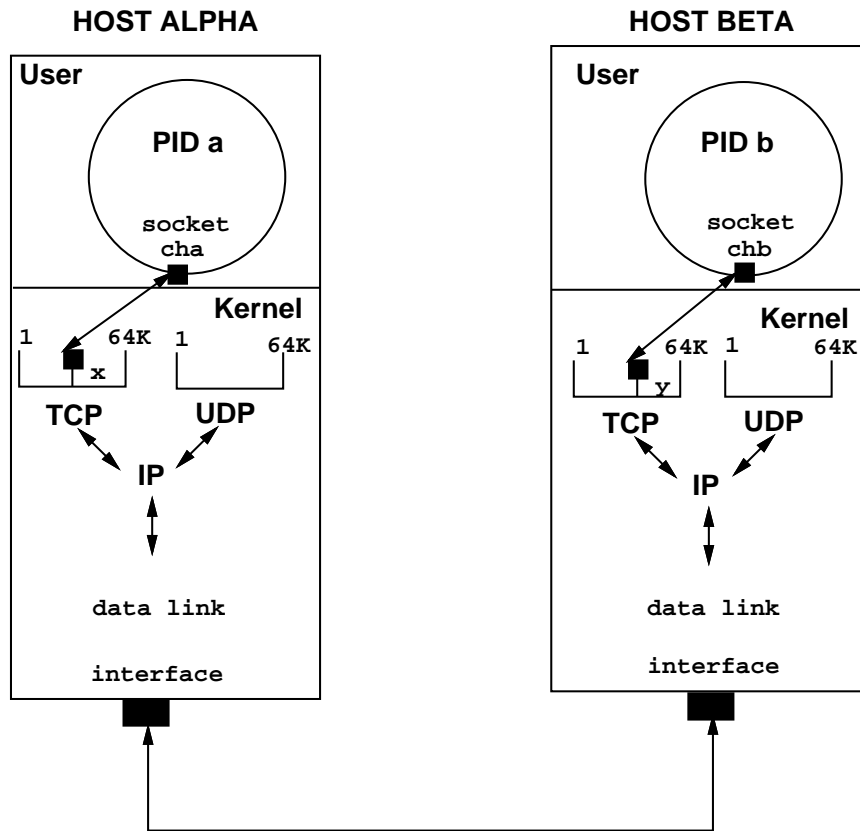

`write(cha, buf, sizeof(buf));`

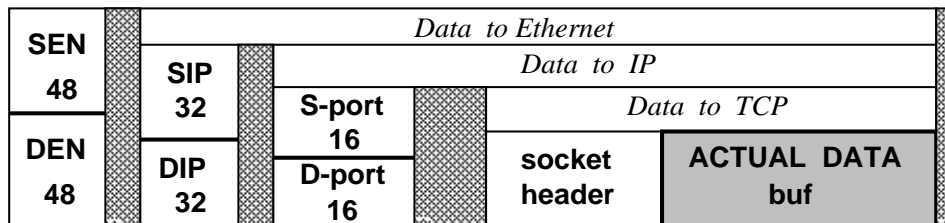

PID a writes to PID b over a TCP connection using PORT **x** on HOST ALPHA and PORT **y** on HOST BETA. After the connection is established, simple `read()` and `write()` calls can be used with channels **cha** and **chb**

Socket Interhost IPC (Cont'd)

SYNOPSIS

Create an endpoint for communication

```
#include <sys/socket.h>
#include <netinet/in.h>
```

```
int  socket (af, type, protocol)
int  af;
int  type;
int  protocol;
```

where:

af	Address family (domain)
type	Type of service desired
protocol	Optional protocol id (usually 0)

	possible family values
AF_UNIX	local host domain
AF_INET	internet domain

	possible service type values
SOCK_STREAM	virtual circuit socket
SOCK_DGRAM	datagram socket
SOCK_RAW	access to internal network

returns: channel number on success, or -1

Socket Interhost IPC (Cont'd)

SYNOPSIS

Create a pair of connected UNIX domain sockets

```
#include <sys/socket.h>
```

```
int  socketpair (af, type, protocol, sv)
int  d;
int  type;
int  protocol;
int  sv[2];
```

where:

af	Address family (domain) of the socket, AF_UNIX
type	Type of service, SOCK_STREAM/SOCK_DGRAM
protocol	Protocol of interest, 0 for default
sv	Buffer in which to return descriptors

DESCRIPTION

The `socketpair` call is used in the UNIX domain only to create a connected pair of sockets in the style of the `pipe()` call. A creator would typically `fork()` a child (or children) and use the channel inheritance of the offspring for full duplex IPC. Unlike a pipe, both channel descriptors are open for reading and writing with no possible crosstalk.

returns: 0 on success, or -1

Socket Interhost IPC (Cont'd)

SYNOPSIS

Initiate a connection on a socket

```
#include <sys/socket.h>
#include <netinet/in.h>
#include <sys/un.h>
```

```
int    connect (s, name, namelen)
int    s;
const struct sockaddr * name;
int    namelen;
```

where:

s The file descriptor of a socket to connect
name Name of peer or listening socket through
 which the connection will be made
namelen Length of name (bytes)

 possible name address formats

```
struct sockaddr_un{
    short sun_family;           /* AF_UNIX     */
    char sun_path[109];        /* UNIX file path */
};
struct sockaddr_in{
    short    sin_family;           /* AF_INET     */
    u_short sin_port;           /* port number */
    struct in_addr sin_addr;   /* inet addr   */
    char    sin_zero[8];
}
}
```

returns: 0 on success, or -1

Sockaddr Format Types

struct sockaddr_un

byte size : 2	AF_UNIX
byte size : up to 109 the size is the number of characters in the path name	/usr/users/bill/sock

length argument:
sizeof (short) + strlen (pathname)

struct sockaddr_in

byte size : 2	AF_INET
byte size : 2	PORT # (1 - 64k)
byte size : 4	IP ADDRESS
byte size : 8	PADDING

length argument:
sizeof (struct sockaddr_in)

Socket Interhost IPC (Cont'd)

SYNOPSIS

Bind a name to a socket

```
#include <sys/socket.h>
#include <netinet/in.h>
#include <sys/un.h>
```

```
int    bind (s, name, namelen)
int    s;
const struct sockaddr * name;
int    namelen;
```

where:

```
s          Socket to bind
name       Name to bind to socket
namelen   Length of name (bytes)
```

DESCRIPTION

This call allows a process to establish a link to an underlying TCP or UDP port (in the case of an internet socket) or a link to a path name in the file system (in the case of a UNIX domain socket). In general, a server must use this call to give herself an address, whereas a client is not required to use this call (but may if she so chooses), but is automatically allocated a source port at the time a connect() call is made. It can be seen that the call arguments are the same as those for the connect call.

returns: 0 on success, or -1

Socket Interhost IPC (Cont'd)

SYNOPSIS

Listen for connections on a socket

```
int listen (s, backlog)
int s;
int backlog;
```

where:

s File descriptor of socket to listen on.
backlog Maximum number of waiting connections.

returns: 0 on success, or -1

SYNOPSIS

```
#include <sys/socket.h>
#include <netinet/in.h>
#include <sys/un.h>
```

```
int accept (s, addr, addrlen)
int s;
struct sockaddr * addr;
int * addrlen;
```

where:

s Socket channel listening for connection requests
addr Structure to receive the address of connected peer
addrlen On input contains the number of bytes available for the peer address; updated to indicate the number of bytes returned

returns: Connected new channel number, or -1

Unix Domain Socket IPC

EXAMPLE:

Client/Server example using UDS

The client code

```
/*  client process for UNIX domain socket example  */
#include <sys/types.h>
#include <sys/socket.h>
#include <sys/un.h>

int main(int argc, char *argv[])
{
    int  sock, nread;
    char buf[256];
    struct sockaddr_un nameformat;

    sock = socket(AF_UNIX, SOCK_STREAM, 0);
    nameformat.sun_family = AF_UNIX;
    strcpy(nameformat.sun_path, "/usr/users/bill/socket");

    /*  connect to name in file system  */
    /*  notice size of address value  */

    if ( connect(sock, &nameformat,
                strlen(nameformat.sun_path)
                + sizeof(nameformat.sun_family) ) == -1)
        exit(1);
    write(sock, "hello from client", 17);
    nread = read(sock, buf, sizeof(buf));
    *(buf + nread) = '\0';
    printf("server's message is:  %s\n", buf);
    close(sock);
    return(1);
}
```

Unix Domain Socket IPC Cont'd

EXAMPLE:

Client/Server example using UDS

The server code

```
/*  server process for UNIX domain socket example  */
#include <sys/types.h>
#include <sys/socket.h>
#include <sys/un.h>

int main(int argc, char *argv[])
{
    int  sock, newsock, nread;
    char buf[256];
    struct sockaddr_un nameformat;

    sock = socket(AF_UNIX, SOCK_STREAM, 0);
    nameformat.sun_family = AF_UNIX;
    strcpy(nameformat.sun_path, "/usr/users/bill/sock");
    unlink(nameformat.sun_path);

    /*  bind to name in file system      */
    /*  notice size of address value    */

    if (bind(sock, &nameformat,
              strlen(nameformat.sun_path)
              + sizeof(nameformat.sun_family)) == -1)
        exit(1);
}
```

Unix Domain Socket IPC Cont'd

EXAMPLE:

Client/Server example using UDS cont'd

The server code

```
listen(sock,3);

for(;;)                /* forever */
{
    if( (newsock = accept(sock, NULL, NULL)) == -1){
        perror("accept failed: ");
        exit(2);
    }

    if (fork() == 0){    /* child */
        close(sock);
        nread = read(newsock, buf, sizeof(buf));
        *(buf + nread) = '\0';
        printf("client's message is: %s\n", buf);
write(newsock, "Server is closing connection", 28);
        close(newsock);
        exit(0);
    }

    close(newsock);
}
}
```

Example With Internet Sockets

EXAMPLE:

Client/Server example using internet sockets

A "one-time" FTP client

```
/*          client.c  a minimal FTP client          */
/*  this version works on all BSD based  systems  */

#include <stdio.h>
#include <sys/types.h>
#include <sys/socket.h>
#include <netinet/in.h>
#include <netdb.h>
#include <fcntl.h>
#include <strings.h>

#define MSG_BODY  248
#define MSG_SIZE  (MSG_BODY+8)
#define PORT      27439
#define SEND      1
#define RECV      2
#define DATA     100
#define END_DATA  101

typedef  struct{
    int  mtype;
    int  msize;
    char mbody[MSG_BODY];
} MSG;

typedef union{
    MSG m;
    char buf[MSG_SIZE];
} MBUF;
```

Example With Internet Sockets Cont'd

EXAMPLE:

Client/Server example using internet sockets cont'd

A "one-time" FTP client

```
main(int argc, char *argv[])
{
    MSG      msg;
    MBUF     raw;
    int      inet_sock, local_file;
    int      type_val, size_val, read_val, local_size;
    int      i,j,k;
    char     *buffer_ptr, *token_ptr, *last_token_ptr;
    union type_size;
    struct sockaddr_in inet_telnum;
    struct hostent *heptr, *gethostbyname();

    if((inet_sock=socket(AF_INET, SOCK_STREAM, 0)) == -1){
        perror("inet_sock allocation failed: ");
        exit(1);
    }

    if((heptr = gethostbyname( argv[1] )) == NULL){
        perror("gethostbyname failed: ");
        exit(1);
    }

    bcopy(heptr->h_addr, &inet_telnum.sin_addr, heptr->h_length);
    inet_telnum.sin_family = AF_INET;
    inet_telnum.sin_port = htons( (u_short)PORT );

    if(connect(inet_sock, &inet_telnum, sizeof(struct sockaddr_in)) == -1){
        perror("inet_sock connect failed: ");
        exit(2);
    }
}
```

Example With Internet Sockets Cont'd

EXAMPLE:

Client/Server example using internet sockets cont'd

A "one-time" FTP client

```
msg.mtype = htonl(RECV);
strcpy(msg.mbody, argv[2]);
local_size = strlen(argv[2]) + 1;
msg.msize = htonl(local_size);

token_ptr = strtok(argv[2], "/");

do{
    if((last_token_ptr = token_ptr) == NULL){
        printf("\n    *** Illegal path name, terminating\n\n");
        exit(2);
    }
} while(token_ptr = strtok(NULL, "/"));

if((local_file=open(last_token_ptr, O_RDWR | O_CREAT | O_TRUNC, 0666))
    == -1){
    perror("local_file open failed: ");
    exit(3);
}

if(write(inet_sock, &msg, local_size + (2*sizeof(int))) == -1){
    perror("inet_sock write failed: ");
}

if(write(inet_sock, &msg, local_size + (2*sizeof(int))) == -1){
    perror("inet_sock write failed: ");
    exit(3);
}
```

Example With Internet Sockets Cont'd

EXAMPLE:

Client/Server example using internet sockets cont'd

A "one-time" FTP client

```
while(1){
    for(i=0; i<(2*sizeof(int)); i++){
        if(read(inet_sock, raw.buf+i, 1) != 1){
            perror("read type_size failed: ");
            exit(3);
        }
    }
    type_val = ntohl(raw.m.mtype);
    size_val = ntohl(raw.m.msize);
    read_val = size_val;
    buffer_ptr = raw.buf;
    switch(type_val){
        case DATA:
            while ((j = read(inet_sock, buffer_ptr, read_val)) != read_val){
                switch(j){
                    default: read_val -= j;
                            buffer_ptr += j;
                            break;
                    case -1: perror("inet_sock read failed: ");
                            exit(3);
                    case 0: printf("unexpected EOF on inet_sock\n");
                            exit(4);
                }
            }
            if(write(local_file, raw.buf, size_val) == -1){
                perror("local write failed: ");
                exit(3);
            }
            break;
        case END_DATA:
            printf("transfer of %s completed successfully, goodbye\n",argv[2]);
            exit(0);
        default:
            printf("unknown message type %d size of %d\n",type_val,size_val);
            printf("this is an unrecoverable error, goodbye\n");
            exit(5);
    }
}
}
```

Example WithInterhost IPC with Internet Sockets Cont'd

EXAMPLE:

Client/Server example using internet sockets cont'd
The simple FTP demon server

```
/* server.c a minimal ftp */

#include <stdio.h>
#include <sys/types.h>
#include <sys/socket.h>
#include <netinet/in.h>
#include <netdb.h>
#include <fcntl.h>
#include <signal.h>
#include <errno.h>

#define MSG_BODY 248
#define MSG_SIZE (MSG_BODY+8)
#define PORT 27439
#define SEND 1
#define RECV 2
#define DATA 100
#define END_DATA 101

typedef struct{
    int mtype;
    int msize;
    char mbody[MSG_BODY];
} MSG;

typedef union{
    MSG m;
    char buf[MSG_SIZE];
} MBUF;

extern int errno;

void child_handler(sig){
    wait(NULL);
}
```

Example With Interhost IPC with Internet Sockets Cont'd

EXAMPLE:

Client/Server example using internet sockets cont'd
The simple FTP demon server

```
main(int argc, char *argv[])
{
    MSG      msg;
    MBUF     raw;
    int      inet_sock, new_sock, local_file;
    int      type_val, size_val, read_val;
    int      i,j,k,fromlen;
    char     *buffer_ptr;
    union type_size;
    struct sockaddr_in inet_telnum;
    struct hostent *heptr, *gethostbyname();
    int      wild_card = INADDR_ANY;
    struct sigaction sigstrc;

    sigstrc.sa_handler = child_handler;
    sigstrc.sa_mask = 0;
    sigstrc.sa_flags = SA_NOCLDSTOP;
    sigaction(SIGCHLD, &sigstrc, NULL);

    if((inet_sock=socket(AF_INET, SOCK_STREAM, 0)) == -1){
        perror("inet_sock allocation failed: ");
        exit(1);
    }
    bcopy(&wild_card, &inet_telnum.sin_addr, sizeof(int));
    inet_telnum.sin_family = AF_INET;
    inet_telnum.sin_port = htons( (u_short)PORT );
    if(bind(inet_sock, &inet_telnum, sizeof(struct sockaddr_in)) == -1){
        perror("inet_sock bind failed: ");
        exit(2);
    }
    listen(inet_sock, 5);
```

Example WithInterhost IPC with Internet Sockets Cont'd

EXAMPLE:

Client/Server example using internet sockets cont'd
The simple FTP demon server

```
for(;;){                                /* forever */

    while((new_sock = accept(inet_sock, &inet_telnum, &fromlen)) == -1 &&
           errno == EINTR);

    if(new_sock == -1){
        perror("accept failed: ");
        exit(2);
    }
    switch(fork()){
        default: close(new_sock);
                break;

        case -1: perror("fork failed: ");
                 exit(1);

        case 0: close(inet_sock);
                 while(1){
                     for(i=0; i<(2*sizeof(int)); i++){
                         if(read(new_sock, raw.buf+i, 1) != 1){
                             perror("read type_size failed: ");
                             exit(3);
                         }
                     }
                 }

                 type_val = ntohl(raw.m.mtype);
                 size_val = ntohl(raw.m.msize);
                 read_val = size_val;
                 buffer_ptr = raw.buf;
                 read_val = size_val;
                 buffer_ptr = raw.buf;
```

Example With Interhost IPC with Internet Sockets Cont'd

EXAMPLE:

Client/Server example using internet sockets cont'd

The simple FTP demon server

```
switch(type_val){
  case RECV:
    while ((j=read(new_sock, buffer_ptr, read_val)) != read_val){
      switch(j){
        default: read_val -= j;
                  buffer_ptr += j;
                  break;
        case -1: perror("new_sock read failed: ");
                  exit(3);

        case 0:  printf("unexpected EOF on new_sock\n");
                  exit(4);
      }
    }
    if((local_file = open(raw.buf, O_RDONLY, 0)) == -1){
      perror("local open failed: ");
      exit(3);
    }
    while(1){
      switch(j=read(local_file, msg.mbody, MSG_BODY)){
        default: msg.msize = htonl(j);
                  msg.mtype = htonl(DATA);
                  if(write(new_sock, &msg, (2*sizeof(int)+j))
                     == -1){
                    perror("new_sock write failed: ");
                    exit(3);
                  }
                  break;
        case 0:  msg.msize = htonl(0);
                  msg.mtype = htonl(END_DATA);
                  if(write(new_sock, &msg, (2*sizeof(int)))
                     == -1){
                    perror("new_sock write failed: ");
                    exit(3);
                  }
      }
      printf("server done sending file %s\n", raw.buf);
      exit(0);
    }
  }
}
```

Example With Interhost IPC with Internet Sockets Cont'd

EXAMPLE:

Client/Server example using internet sockets cont'd
The simple FTP demon server

```
                case -1: perror("local_file read failed: ");
                        exit(3);
                }
        }
case TEST:
    while ((j=read(new_sock, buffer_ptr, read_val)) != read_val){
        switch(j){
            default: read_val -= j;
                    buffer_ptr += j;
                    break;
            case -1: perror("new_sock read failed: ");
                    exit(3);
            case 0: printf("unexpected EOF on new_sock\n");
                    exit(4);
        }
    }

    printf("server child received test packet number %d as #%d\n",
           *((int *)raw.buf), test_id++);

    sleep(sleep_interval);
    break;

case END_TEST:
    printf("server child finished test run, goodbye\n\n");
    exit(0);

default:
    printf("unknown message type %d claims size of %d\n",
           type_val, size_val);
    printf("this is an unrecoverable error, goodbye\n");
    exit(5);
}
}
}
}
```